

# Analytical Discussion of Single Electron Transistor (SET)

Vinay Pratap Singh, Arun Agrawal, Shyam Babu Singh

**Abstract:** Single-electron transistor (SET) is a key element of current research area of nanotechnology which can offer low power consumption and high operating speed. Single electron transistor [SET] is a new nanoscaled switching device because single-electron transistor retains its scalability even on an atomic scale and besides this; it can control the motion of a single electron. Here, scalability means that the performance of electronic devices increases with a decrease of the device dimensions. Since, Power consumption is roughly proportional to the electron number transferred from voltage source to the ground in various logic operations. Therefore, the single-electron transistor [SET] is generally utilized as an ULSI element to reduce the power consumption of ULSIs. Thus, the Single electron transistor [SET] can offer low power consumption and the controlled tunneling of a single electron makes its high operating speed. The goal of this paper is to discuss about the basic physics of nano electronic device 'Single electron transistor [SET]' which is capable of controlling the transport of only one electron. In this paper, we also focus on some basic device characteristics like 'Coulomb blockade', single electron tunneling effect & 'Coulomb staircase' on which this Single electron transistor [SET] works and the basic comparison of SET & FET characteristics and also its [SET] advantages as well as disadvantages to make a clear picture about the reason behind its popularity in the field of nanoelectronics.

**Index Terms:** Coulomb blockade, Classical theory, Quantum dot, single electron tunneling.

## I. INTRODUCTION

Single-electron transistor (SET) is very popular in the field of nanoelectronics since a decade. Single electron transistor (SET) is the most fundamental three-terminal single electron device (SED) which is capable of offering low power consumption and high Operating speed. Since the technology reaches nano size, the behavior of a nanoelectronic single electron transistor (SET) is controlled by the quantum mechanical effects.

The schematic structure of SET is shown in fig. 1. As shown in fig. 1, the schematic structure of SET is almost same as that of MOSFET. A single electron transistor (SET) may be considered as a field effect transistor (FET) whose channel consist of a small, low capacitance (C), conducting Island [Quantum Dot] which is coupled to the source and drain leads by two tunnel junctions and capacitively coupled to one or more gate which is used to control the transfer of

single electron from source to drain. Here, the tunnel junction is nothing but a thin insulating barrier between two conducting electrodes. The SET is operated in a single electronics regime in which only one electron can transfer from source to drain via island under the application of constant gate voltage on the island. Single electron device is based on an intrinsically quantum phenomenon known as the Tunnel effect. This single electron tunneling technology presents the ability to control the transfer of individual electrons. Single electron transistor (SET) can be operated as sensitive, linear charge amplifier, through the exploitation of this single electron quantum tunneling effect. SETS have

charge sensitivity on the order of  $10^{-6} e/(HZ)^{\frac{1}{2}}$ . This represents that a charge variation of  $10^{-6} e$  can be detected in a measurement time of 1 second. The two main processes that take place in this nano structured electronic device are Coulomb blockade and single electron tunneling.

Recently, a single electron transistor SET is considered as an element of a future low power, high density integrated circuit because of a possible ultra low power operation with a few electrons. For the practical application, it is absolutely necessary for the SET to be operated at room temperature. For this rpose, the size of the island of SET must be as small as possible. Generally, the size of island is considered as 10 nm for practical applications to reduce the total capacitance of SET and to overcome the problems of the thermal fluctuation.

## II. CONCEPT OF SINGLE ELECTRONICS

Single electronics is the fundamental concept behind single electronic devices like single electron transistors (SETs) that can be explained by assuming a small metallic sphere, as shown in fig 2. , which is initially electro-neutral i.e. the net charge on this sphere is zero because of the same number of electrons and protons in it. Now, consider that a single electron is positioned close to the sphere. In this situation, it gets attracted by the sphere. Thus, this single electron joins the sphere and leaves a negative charge of  $-e$  on it. Now, due to the presence of this negative charge, an electric field is created around the sphere so that if any other electron comes close to this sphere, it will face a strong repulsive force exerted by the electric field created around the sphere.

**Manuscript received on July 2012.**

**Vinay Pratap Singh**, M.Tech. Student, I.T.M. Universe, Gwalior.

**Arun Agrawal**, Assistant Professor, CS dept., I.T.M. University, Gwalior (M.P.), India

**Shyam Babu Singh**, Assistant Professor, EI dept., I.T.M. Universe, Gwalior (M.P.), India

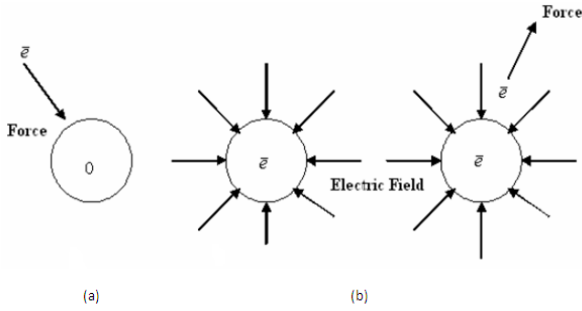

**Fig. 1** a) an electron feeling a small attractive force as it approaches a sphere. b) Once sphere gets charge by a single electron; other electrons will feel a strong repelling force.

The concept behind the single electronics shows that the more accurate measurement of the strength of this tunneling effect is charging energy or electrostatic energy, which is given by:  $E_c = e^2/2c$ .

From the above given equation, it is clear that if capacitance is very small, the charging energy may be dominating. The phenomena of single-electron transfer may be easily understood, if the concept about the movement of electronic charge through a conductor is clear. The current flows through a conductor in a continuous manner because the number of free electrons is available in it. This current may be determined by calculating the charge transferred through the conductor per time interval. Since, the charge transferred through the conductor may have any value, therefore it is not quantized. In this case, the transfer of charge through the conductor is a continuous quantity because the electron cloud shift against the lattice of the atoms may not be quantized in a conductor. This picture is shown in fig.2.

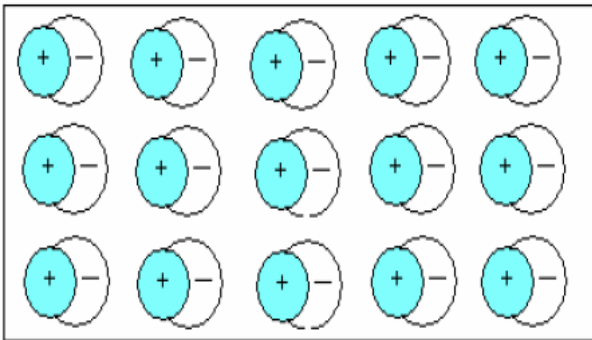

**Fig. 2** charge flow in a good conductor

Now, if a tunnel junction is placed in an ordinary conductor, the flow of electrons penetrating this thin insulating barrier will be restricted by it. This is shown in fig. 3.

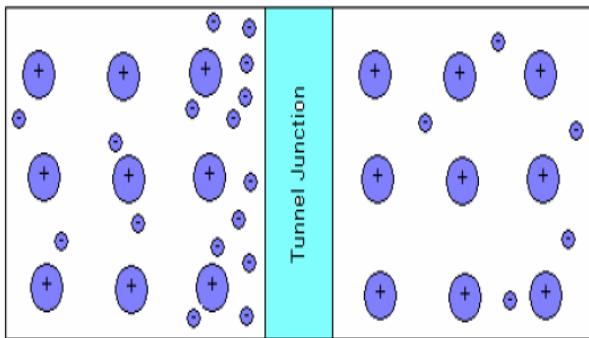

**Fig. 3** Tunnel junction in an ordinary conductor.

Thus, the current through a conductor may be quantized in this situation. The electric charge may be moved by both continuous and discrete process due to the application of tunnel junction as an insulating barrier in an ordinary conductor. Now, if discrete electrons can tunnel through the junction, the charge will be accumulated at the tunnel junction. When a high bias voltage is applied across this junction, one electron gets transferred. K.K. Ikharev has described this single electron tunneling phenomenon as dripping tap. In other words, if the tunnel junction is biased with constant current  $I$ , single electron tunneling oscillation will be appeared with frequency  $f = I/e$ . This analogy is represented by the following fig. 4.

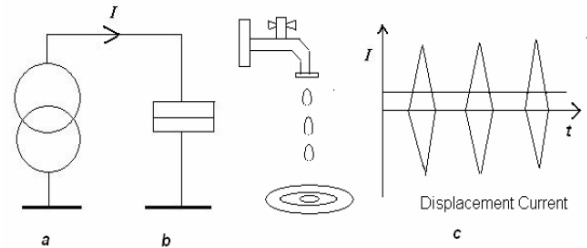

**Fig. 4** Current biased tunnel junction and coulomb oscillation (a) circuit diagram (b) Dripping tap (c) tunneling oscillations.

The charging and discharging of tunnel junction and thermal fluctuations are closely related to each other. Since, the thermal fluctuations can disturb the motion of the electrons and can suppress the quantization effects. Therefore, to avoid this problem, coulomb energy must be greater than the thermal fluctuations. Thus, the required condition to observe the single electron phenomenon is as follows:

$$E_c = e^2/2c > k_B T$$

Where  $k_B$  is Boltzmann's constant and  $T$  is temperature in Kelvin.

There are two fundamental conditions to observe the charging effect at room temperature. First condition is that the capacitance  $C$  must be smaller than  $3af$ . The second condition is that the quantum fluctuations of number of electrons must be negligible i.e. the electrons should be localized only on the island and all tunnel junctions should be opaque for electrons to confine them to the islands. This required condition of opacity can be maintained if tunnel resistance  $R_T$  is larger than the quantum resistance. i.e.

$$R_T > h/e^2 = 25.813 \text{ K}\Omega$$

Where  $h$  is plank's constant and  $e$  is electronic charge.

### III. SET SCHAMATIC AND IT'S WORKING

Single-electron transistors (SETs) are essential elements of ULSI logic circuit design. A three terminal switching device in which the effect of coulomb blockade can be observed is generally known as single-electron transistor. Unlike field-effect transistors, single-electron transistors are based on an intrinsically quantum phenomenon which is known as 'Tunnel effect'. This tunnel effect may be observed when two metallic electrodes are separated by an insulating barrier known as tunnel junction.

These three terminal switching devices can transfer electrons from source to drain one by one. The schematic structure of SETs is shown in fig. 5.

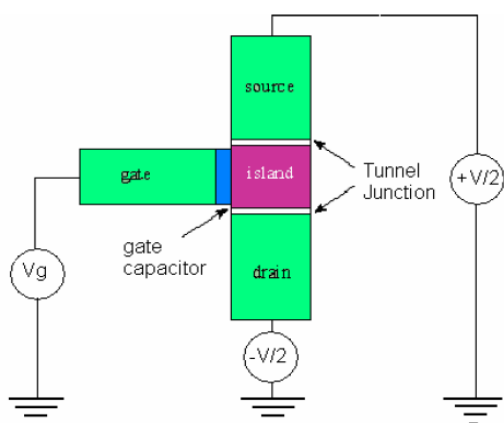

**Fig. 5 Schematic structure of a SET**

Quantum dot which is less than 100 nm in diameter is a mesoscopic system in which the electrostatic energy or coulomb energy can be changed due to removal or addition of a single electron that is greater than the thermal energy and can control the electron transport into and out of the quantum dot. In other words, Quantum dot is a small conducting island that contains a tunable number of electrons occupying discrete orbitals.

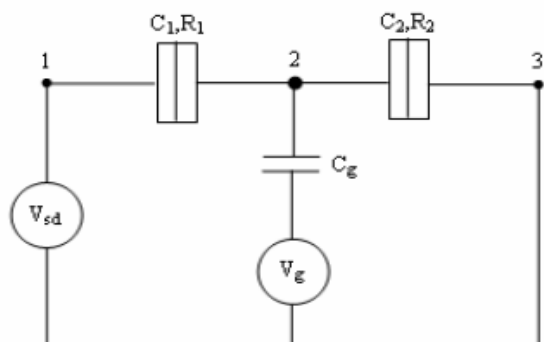

**Fig. 6 Single electron transistor circuits with Single Island**

As shown in fig 6 & 7, Single electron transistor circuits are made of small tunnel junctions, capacitances, and voltage sources. A gate voltage  $V_g$  is used to control the opening and closing of the SET or in other words, it controls one-by-one electron transfer. Here, a tunneling electron can be described as a discrete charge due to stochastic nature of a tunneling event. In Figures 6 & 7, node 1 represents source electrode, node 2 (and 4) is island, and node 3 represents drain electrode. The tunnel junctions are located in between these nodes, which are described by tunnel capacitance and tunnel resistance.

The single electron tunneling theory depends on the 'Orthodox theory' which focuses on charging of the small conducting island. of diameter  $\leq 100$  nm. The capacitance of island is given by the equation for a Conducting spherical capacitance  $C = 2\pi\epsilon_0\epsilon d$ .

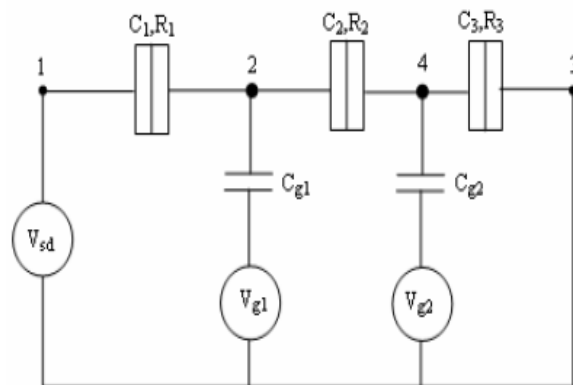

**Fig. 7 Single electron transistor circuits with Dual Island**

As SET is composed of two tunnel junctions along with one island which are capacitively coupled to gate electrode. The island is located in between two tunnel junctions with capacities  $C_1$  and  $C_2$ . SET can electrostatically be controlled by the gate capacitance  $C_g$ . Thus the total capacitance of the island is given by

$$C_{\Sigma} = C_1 + C_2 + C_g \quad (1)$$

Thus, such a set up is called single electron transistor.

#### IV. PRINCIPLE OF SINGLE-ELECTRON TUNNELING & COULOMB BLOCKADE

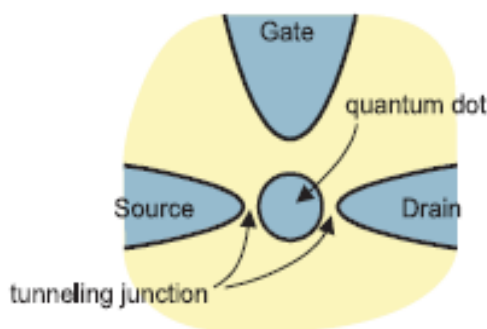

**Fig. 8 Schematic structure of SET showing tunnel junctions.**

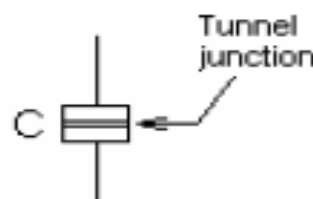

**Fig. 9 Tunnel junction or Insulating Barrier**

As shown in fig 8 & 9, a tunnel junction is considered as a thin insulating barrier between two conducting electrodes. In case of classical electrodynamics, no current can flow through an insulating barrier. But according to the quantum mechanics approach, there is some probability (i.e. greater than zero) for an electron located at one side of the barrier (tunnel junction) to reach the other side. Thus, the transfer of electrons through the barriers between the quantum dots would result in charging of the neighboring quantum dots. Now,

this would result in an increase of the electrostatic energy which is given by

$$E_C = \frac{e^2}{2C} \quad (2)$$

Where C is the effective capacitance of the island. Later on, this electrostatic energy  $E_C$  became known as Coulomb charging energy or coulomb blockade energy. This coulomb blockade energy is the repelling energy of previous electron present in the island to the next electron coming towards the island. In case of a tiny system, the capacitance C of the island is very small. Thus, according to equation (2), the coulomb charging or blockade energy ( $E_C$ ) will be very high and due to this reason, electrons are unable to move simultaneously, but pass one-by-one. Thus, this coulomb charging energy or coulomb blockade energy is responsible for the suppression of the electrons transfer simultaneously. This phenomenon is known as ‘‘Coulomb blockade.’’ The suppression of electron transfer can be removed by one of these two possible cases:

(a) When the coulomb charging energy is overcome by thermal excitations at a temperature T, i.e

$$T \sim T_0 = \frac{E_C}{k_B} \quad (3)$$

(b) When the coulomb charging energy is overcome by an externally applied voltage V, i.e.

$$V \sim V_T = \frac{E_C}{e} = \frac{e}{2C} \quad (4)$$

Where,  $V_T$  is known as ‘Threshold voltage’ which is defined as an applied voltage that is just sufficient to increase the energy of electron above the coulomb blockade of tunneling so that the current can start to flow though the tunnel junction (Barrier) .

This suppression of electron transfer is normally termed as ‘Coulomb blockade (CB) of tunneling. Thus, it is clear that if the voltage V is less than the threshold voltage  $V_T$ , the system is in Coulomb blockade (CB) state. In case, when the voltage V exceeds  $V_T$ , an electron tunnels through the barrier (tunnel junction) into the quantum dot.

Fig. 6 & 7 represents the single electron circuits with Single Island and with double island. For making the concept of coulomb blockade of tunneling more clearly, we again consider the single electron circuits in which on applying bias voltage, there will be a current flow. Now, if we avoid additional effects, in that case, the first- order-approximation- tunneling current is proportional to the applied bias voltage. In other words, we can say that a tunnel junction behaves like a resistor of a constant value which depends on the barrier thickness. Since, the tunnel junction is composed of two conductors and an insulating layer in between these two conductors. Therefore, tunnel junction is described by the tunnel resistance R and tunnel capacitance C. In this case, tunnel junction acts as a capacitor and the insulating layer works as a dielectric medium for tunnel capacitor C. The current flowing through a tunnel junction is a series of events in which only one electron passes through the tunnel junction because of discrete nature of charge. As electron tunnels the junction, tunnel capacitance is charged

with an elementary charge building up a voltage which is represented by  $V = e/C$ . If the capacitance of the tunnel junction is very small, the voltage developed in the tunnel junction may be sufficient to prevent another electron to tunnel. Now, in this situation, the electric current is suppressed if the bias voltage is lower than the voltage developed in the tunnel junction. Thus the increment of the tunnel junction resistance around zero bias is considered as the coulomb blockade. Therefore, coulomb blockade may be defined as the increased tunnel junction resistance at very low bias voltages of an electronic device which consists of at least one low capacitance tunnel junction.

The coulomb blockade can be achieved only if, in case, when the following three conditions meet:

1. The bias voltage must be lower than the elementary charge divided by the self-capacitance of the island. i.e.  $V_{bias} < e/C$
2. The thermal energy  $K_B T$  must be below the charging energy i.e.  $K_B T < e^2/C$ ; or else the electron will be able to pass the quantum dot (QD) via thermal excitation.
3. The tunneling resistance ( $R_T$ ) should be greater than  $h/2\pi e^2$  which is derived from ‘Heisenberg’s uncertainty principle’. i.e.  $R_T > h/2\pi e^2 = 25813\Omega$

This is the required condition for tunnel resistance.

## V. CLASSICAL THEORY FOR SET OPERATION

The classical theory for single electron transistors (SETs) is a quantum mechanical analysis which describes the electron transport through these devices and also explains about the origination of coulomb blockade in these devices.

In this classical approach, the energy that determines the transport of electrons through a single electron transistor is ‘Helmholtz’s free energy (F). This energy may be defined as the difference between the total energy stored in a SET (denoted by  $E_\Sigma$ ) and the work done by the power sources (denoted by W). i.e.

$$F = E_\Sigma - W \quad (5)$$

Where, the total energy stored in a SET includes all three components that have to be considered in case when an island is charged with an electron. Thus, total energy stored in a SET may be written as:

$$E_\Sigma = E_C + \Delta E_F + E_N \quad (6)$$

The change in Helmholtz’s free energy indicates the measurement of the probability of the tunneling event for the electrons.

Following are the three three components of total energy stored in a SET ( $E_\Sigma$ ):

### A. Electron-Electron Interaction ( $E_C$ )

The classical model for electron-electron interaction is based on the electrostatic capacitive charging energy. The fact behind the electron-electron interaction is that when an additional charge dq is transported to a conductor, work has to be done against the field that is produced by already present charges on that conductor.

The basic requirement for an island with a capacitance  $C$  that can be charged with an electron of charge 'e' is given by:

$$E_C = e^2/2C \quad (7)$$

**B. Fermi Energy ( $\Delta E_F$ )**

All single-electronics systems having small islands also exhibit a second electron-electron interaction energy, which is commonly known as 'Fermi energy'. This Fermi energy may be changed when the island is charged with a single electron.

**C. Quantum Confinement Energy ( $E_N$ )**

In case of single electron transistor, as island size decreases, the energy level spacing of electron states increases in the same proportion which is indirectly proportional to the square of the quantum dot size. By taking an infinite potential and a simple model for a quantum dot, this Quantum confinement energy may be calculated by solving the following Schrodinger's equation:

$$E_N = \frac{1}{2m} \left( \frac{\hbar N}{2d} \right)^2 \quad (8)$$

**D. Workdone by the the voltage sources (W)**

Since, thermodynamically the interacting island represents an open system. Therefore, the workdone on the system by the power supplies has to be included in order to determine the total available energy for a tunnel event.

**VI. I-V CHARACTERISTICS OF SET**

Fig. 10 shows the IV-Characteristics for the symmetric junction circuit of single electron transistor where  $C_1 = C_2$  and  $R_1 = R_2$ . It is clear from the IV- characteristics of the SET that for  $|V| < e/C_\Sigma$ , the current is zero. This state is called Coulomb blockade that suppresses the tunneling of single electron in case of low bias condition. Now, if the externally applied junction voltage  $V$  is increased up to a level that is above the threshold voltage  $V_c$  by charging energy, this effect of Coulomb blockade can be removed and the current flows. In this situation, the junction behaves like a resistor.

The sequential entrance and leaving of an electron from one junction to another is generally known as 'Correlated tunneling of electrons'.

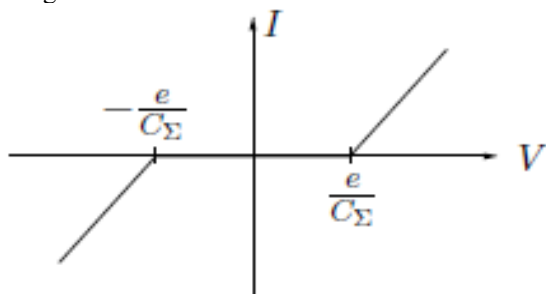

**Fig. 10 IV-characteristics of SET for symmetric junction.**

Fig. 11 represent the IV- Characteristics for a highly asymmetric junction circuit for  $R_1 \ll R_2$ .

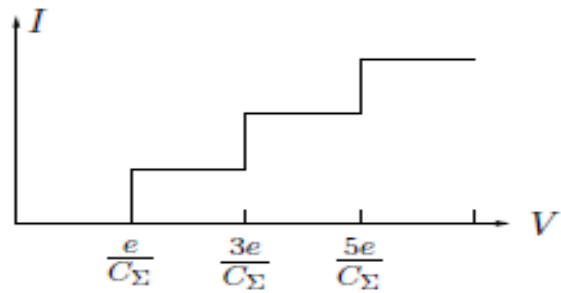

**Fig.11 IV-Characteristics of the SET for asymmetric junction representing 'coulomb Staircase state.'**

In this case, the charge carriers i.e. electrons enter through one junction and then escape to second junction due to the presence of high resistance. Now, electrons moves from one junction to another very rapidly. Thus this rapid movement of excess electrons from one junction to another raises the total charge of the island. If the bias is increased, it will tend to increase the population of electrons in the island. In this case the IV- Curve represents Stair-like characteristics, which are commonly referred to as the 'Coulomb Staircase'.

**VII. DIFFERENCE BETWEEN FET & SET CHARACTERISTICS**

However, the structure of Single electron transistors [SETs] is almost same as that of MOSFETs but still there are some differences between the SETs and MOSFETs such as SETs have tunnel junction in place of p-n junction of the MOSFETs and a small conducting island [quantum dot] in place of channel region of the MOSFETs.

In case of single electron transistor (SET), the tunneling electrons are transferred one-by-one through the channel from source to drain due to the effect of Coulomb blockade. While in case of conventional MOSFET, number of electrons is transferred through the channel at a time. Thus, unlike SET, many electrons simultaneously participate to the drain current. This picture is shown in fig. 12.

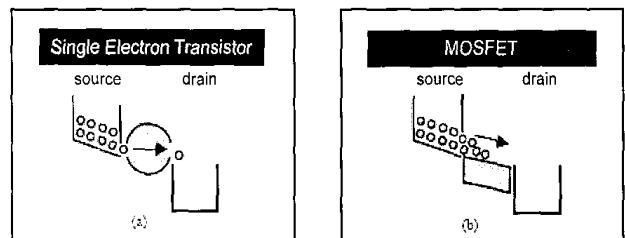

**Fig. 12 Electron tunneling through the channel (a) one-by-one in SET (b) Transfer of many electrons simultaneously through the channel in MOSFET.**

A single electron transistor (SET) is made of an electronic channel connected to one source, one drain and one control gate just like a conventional field effect transistor (FET). But unlike ideal FETs, the source and drain of the SETs are separated from the channel by sufficiently large resistances which are acting as tunnel barriers. In general, the characteristics of SETs and MOSFETs are very different to each other. As one thing is common in both of these two devices which is the electrostatic effect that rules on both of them (i.e. SETs & MOSFETs)



but in case of SETs, electrons are not free to move from source to drain due to the presence of tunnel junctions. Due to the Coulomb blockade effect, an electron approaching a small negative charged region experiences the electrostatic repulsion by the previous electron in that region. This regulates the number of electrons one-by-one in the channel. In case of FETs, the drain current ( $I_d$ ) depends on the number of electrons passes through the channel. i.e. more electrons in the channel, larger the drain current. Hence, the  $I_d$ - $V_g$  characteristic is monotonic. This remains true at low temperature because of the Fermi velocity increases with the density of electrons. In case of SETs, the drain current ( $I_d$ ) does not depend on the number of electrons transferring through the channel or on the Fermi velocity. The  $I_d$ - $V_g$  characteristic of SET is periodic which shows a finite drain current only for the specific gate voltages where the energies for  $N$  and  $N+1$  electron in the channel are degenerated.  $N$  and  $N+1$  level are thermally accessible only in the case when the temperature exceeds the charging energy  $e^2/2C_\Sigma$ . and, thus, the FET behavior is also recovered.

### VIII. ADVANTAGES OF SET

Following are the advantages of Single-electron transistors (SETs):

- Low energy consumption
- High sensitivity
- Compact size
- High operating speed
- Simplified circuit
- Feature of reproducibility
- Simple principle of operation
- Straight forward co-integration with traditional CMOS circuits.
- Performance of Single-electron transistors (SETs) is better than the Field-effect transistors (FETs) because of their compact size.
- Single electron transistors (SETs) have high input impedances and low voltage gain. Besides this, these are also very sensitive to random background charges. Due to this, SETs have replaced the FETs in many applications where low output impedances and large voltage gain is necessary.

### IX. DISADVANTAGES OF SET

Following are the disadvantage of Single-electron transistors (SETs):

- **Integration of SETs in a large scale:** To operate SETS at room temperature, large quantities of monodispersed Nan particles less than 10nm in diameter must be synthesized. But, it is very hard to fabricate large quantities of SETs by traditional optical lithography and semiconducting process.
- It is difficult to link SETs with the outside environment.
- Practically difficult to fabricate Single electron transistors (SETs).

## X. CONCLUSION

This research paper focuses the theoretical discussion of basic principle of Single electron transistor and its importance in the age of nanotechnology to provide low power consumption and high operating speed in the field of ULSI design for the fabrication of various electronic devices.

## REFERENCES

1. Quantum information technology based on single electron dynamics, NIT basic research laboratories Atsugi-shi, 243-0198 Japan, Vol. 1 No.3 June 2003.
2. Konstantin k. Likharev, "Single- electron device and their applications", Proc. IEEE Vol. 87, PP. 606-632, April 1999.
3. Qiaoyan Yu, student member IEEE, "Single-electron devices", Manuscript received Dec. 12, 2006.
4. Andreas Scholze, "Simulation of single-electron devices," Ph.D. dissertation, Univ. of Jena, Germany, 2000.
5. Om kumar and Manjit kaur, "Single electron transistor: Applications & problems", International journal of VLSI design and communication system (VLSICS) Vol. 1, No. 4, Dec. 2010.
6. Gregory S. Dubejsky, "Fabrication and DC characterization of Single electron transfers at low temperature", M.S. Thesis, Queen's Univ. Kingston, Ontario, Canada, Aug. 2007.
7. Souvik Sarkar, A. K. Biswas, Ankush Ghosh, Subir K. Sarkar, "Single electron based binary multipliers with overflow detection", International Journal of engineering, Science and Tech. Vol. 1, No. 1, 2009, PP. 61-73.
8. L. J. Yen, Ahmad Radzi Mat Isa, Karsono Ahmad Dasuki, "Modeling and Simulation of single-electron transistor", et al. / Journal of Fundamental Science 1 (2005) 1-6.
9. Amiza Rasmi & Uda Hashim "Single-electron transistor (SET): Literature Review" journal 2005, koieg University, Malaysia.
10. M. N. Leuenberger and E. R. Mucciolo, Phys. Rev. Lett. 97, 126601 (2009).
11. C. Romeike, M.R. Wegewijs, and H. Schoeller, Phys. Rev. Lett. 96, 196805 (2008).
12. Karan deep, "Simulation and E-beam patterning of single electron transistor" M.S. thesis in electrical engineering, Univ. of Texas at Arlington, Dec. 2006
13. Single Charge Tunneling: Coulomb Blockade Phenomena in Nanostructures, eds. H. Grabert and M. H. Devoret (Plenum Press, New York, 1992)
14. D.V. Averin and K.K Likharev, in Mesoscopic Phenomena in Solids, eds. B.L. Altshuler, P.A. Lee, and R.A. Webb (Elsevier, Amsterdam, 1991)
15. X. Jehl, M. Sanquer, J. Gautier, M.Vinet, "Nanoelectronics with CMOS transistors:electrostatic and quantum effects" International journal of nanotechnology Vol. x, No. x, xxxx

## AUTHORS PROFILE

**Vinay Pratap Singh**, B.Tech., Pursuing his degree in M.Tech. in VLSI design from Institute of technology and Management, Gwalior. He presented a paper in an international conference. He published two papers in national conferences also. His areas of interest are embedded system and Single-electronics.

**Arun agrawal**, M.Tech., At present, He is workins as an Assistant Professor in the department of Cumputer Science Engineering at Institute of Technology and Management, University, Gwalior. His areas of interest are embedded system and single-electronics. He published two international journals, four international papers and two national papers.

**Shyam Babu Singh**, M.Tech., At present, He is working as an Assistant Professor in the department of Electronics and Instrumentation Engineering at Institute of Technology and Management, Universe, Gwalior. His area of interest is VLSI design. He presented two papers in international conferences, four papers in national conferences.