

Modelling and Simulation of Grid Connected Wind Energy System

D Mary, Shinosh Mathew, Sreejith K

Abstract— Modeling and simulation of a grid connected wind-driven electricity generation system has been done. The power conversion unit features a wind-turbine-driven PMSG, a diode rectifier, and a dc/ac inverter. The Permanent Magnet Synchronous Generator (PMSG) offers better performance than other generators because of its higher efficiency and of less maintenance since they don't have rotor current and can be used without a gearbox, which also implies a reduction of the weight of the nacelle and a reduction of costs. Therefore, in this paper the modeling and control of a PMSG is presented. All the components of the wind turbine and the grid-side converter are developed and implemented in MATLAB/Simulink.

Index Terms— Modeling, PMSG, Wind Turbine, Inverter, SVPWM, PLL.

I. INTRODUCTION

In recent years, the electrical power generation from renewable energy sources, such as wind, is increasingly attraction interest because of environmental problem and shortage of traditional energy source in the near future. Nowadays, the extraction of power from the wind on a large scale became a recognized industry. It holds great potential showing that in the future will become the undisputed number one choice form of renewable source of energy. The force that pushes this technology is the simple economics and clean energy. As a consequence of rising fossil fuel price and advanced technology, more and more homes and businesses have been installing small wind turbines for the purposes of cutting energy bills and carbon dioxide emissions, and are even selling extra electricity back to the national grid.

The kinetic energy in the wind is converted into mechanical energy by the turbine by way of shaft and gearbox arrangement because of the different operating speed ranges of the wind turbine rotor and generator. The generator converts this mechanical energy into electrical energy. However, as wind is an intermittent renewable source, the wind source extracted by a wind turbine is therefore not constant. For this reason, the fluctuation of wind power results in fluctuated power output from wind turbine generator. From the point of view of utilities, due to the fluctuation of generator output, it's not appropriate for the generator to be directly connected to the power grid. In order to achieve the condition that the generator output power is suitable for grid-connection, it is necessary to use a controller to manage the output produced by the wind turbine generator.

The control technology relating to large wind turbines is sophisticated in terms of generator speed, and torque control, pitch angle control, and so on.

The function of an electrical generator is providing a means or energy conversion between the mechanical torque from the wind rotor turbine, as the prime mover, and the local load or the electric grid. Different types of generators are being used with wind turbines. The common types of AC generator that are possible candidates in modern wind turbine systems are as follows:

- Squirrel-Cage rotor Induction Generator (SCIG),
- Wound-Rotor Induction Generator (WRIG),
- Doubly-Fed Induction Generator (DFIG),
- Synchronous Generator (With external field excitation),
- Permanent Magnet Synchronous Generator (PMSG).

Recently, permanent magnet synchronous generator (PMSG) is used for wind power generating system because of its advantages such as better reliability, lower maintenance, and more efficient etc. The advantages of PM machines over electrically excited machines can be summarized as follows

- Higher reliability due to the absence of mechanical components such as slip rings,
- No additional power supply for the magnet field excitation.
- Improvement in the thermal characteristics of the PM machine due to the absence of the field losses,
- Higher efficiency and energy yield,
- Lighter and therefore higher power to weight ratio.
- Lower maintenance.

II. SYSTEM DESCRIPTION

The system analyzed is a wind turbine based on PMSG. Due to the low generator speed, the rotor shaft is coupled directly to the generator, which means that no gearbox is needed. The generator is connected to the grid via an AC/DC/AC converter, which consists of an uncontrolled diode rectifier, an internal DC-Link modeled as a capacitor and a PWM inverter. The layout of the electric part is depicted in the following figure1. The design procedures for various parts are explained in detail in the following sections.

Manuscript received on March, 2013.

Dr. D Mary, Electrical Engineering, Government College of Technology, Coimbatore, India.

Shinosh Mathew, Electrical Engineering, Government College of Technology, Coimbatore, India.,

Sreejith K, Electrical Engineering, Government College of Technology, Coimbatore, India.

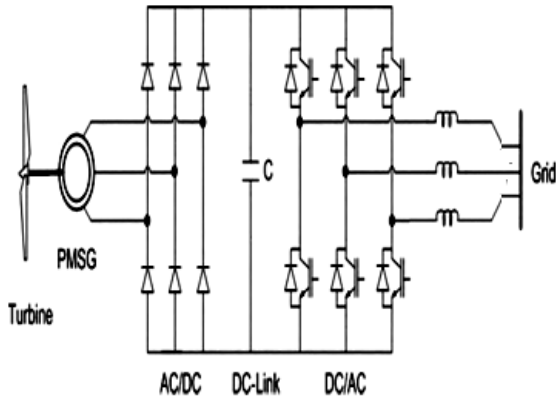

Fig 1 Electrical scheme of a wind turbine equipped with a direct-drive PMSG.

III. SUBSYSTEM MODELS

A. Wind Speed Model

A model is required that can properly simulate the spatial effect of wind behavior, including gusting, rapid (ramp) changes, and background noise. The wind speed is modeled as the sum of the four components listed above.

$$V_w(t) = V_b(t) + V_r(t) + V_g(t) + V_n(t) \quad (1)$$

Where V_b is the base (constant) wind component, V_r is the ramp wind component, V_g is the gust wind component and V_n is the base noise wind component, all of them in m/s. The present work considers a constant wind speed equal to 12 m/s.

B. Wind Turbine Model

The wind turbine analyzed is a classic three-bladed horizontal-axis (main shaft) wind turbine design with the corresponding pitch controller. The output mechanical power available from a wind turbine can be expressed through the following algebraic relation [1],

$$P_m = C_p(\lambda, \beta) \frac{\rho A V^3}{2} \quad (2)$$

Where, ρ - air density

V - Wind Speed

C_p - Coefficient of Performance (or Power Coefficient) of the wind turbine

A - Area swept by the rotor blades of the wind turbine

The power coefficient C_p is a nonlinear function of the blade pitch angle β and the tip-speed ratio λ as given by [1],

$$\lambda = \left(\frac{R\omega_m}{v} \right) \quad (3)$$

Where, ω_m - Angular speed of the turbine rotor

R - Radius of the turbine blades

The power coefficient C_p can be expressed as [10,11],

$$C_p(\lambda, \beta) = C_1 \left(\frac{C_2}{\lambda_i} - C_3\beta - C_4 \right) \exp\left(\frac{-C_5}{\lambda_i}\right) + C_6\lambda \quad (4)$$

Where

$$\frac{1}{\lambda_i} = \frac{1}{\lambda + 0.08\beta} - \frac{0.035}{\beta^3 + 1} \quad (5)$$

The torque of the wind turbine would be expressed as

$$T = \frac{1}{2} C_t(\lambda, \beta) \rho A V^3 \quad (6)$$

With, $C_t(\lambda, \beta) = C_p(\lambda, \beta)/\lambda$, which is called as the torque coefficient of wind turbine.

C. Drive Train Model

Two mass drive train model is utilized in this paper. The equations governing its mechanical dynamics are represented as follows [3],

$$2H_t \frac{d\omega_t}{dt} = T_m - T_{sh} \quad (7)$$

$$\frac{1}{\omega_{elb}} \frac{d\theta_{tw}}{dt} = \omega_t - \omega_r \quad (8)$$

$$2H_g \frac{d\omega_r}{dt} = T_{sh} - T_g \quad (9)$$

Where H_t is the inertia constant of the turbine, H_g is the inertia constant of the PMSG, θ_{tw} is the shaft twist angle, ω_t is the angular speed of the wind turbine in p.u., ω_r is the rotor speed of the PMSG in p.u., ω_{elb} is the electrical base speed, and the T_{sh} shaft torque is expressed as [5],

$$T_{sh} = K_{sh}\theta_{tw} + D_t \frac{d\theta_{tw}}{dt} \quad (10)$$

Where, K_{sh} is the shaft stiffness and D_t is the damping coefficient.

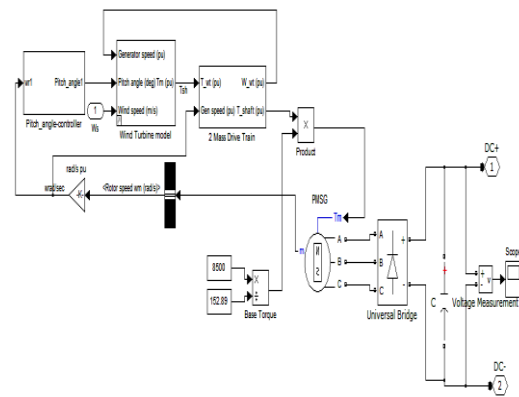

Fig 2 Simulink Model of Wind turbine and Controller

D. Pitch Controller

The turbine has a pitch control system for each blade. Each pitch control system is a servo loop which will make the pitch follow a given reference as quickly as possible and with sufficient damping. The pitch controller is a non-linear controller which compensates for the dead band and the limitations in the proportional valve. When the wind velocities are higher than rated, the maximum energy captured must be limited using pitch control by modifying β : the pitch angle will increase until the machine is at the rated speed [11].

E. PLL Technique

Phase - Locked Loop (PLL) is a phase tracking algorithm widely applied in communication technology, being able to provide an output signal synchronized with its reference input in both frequency and phase. Here, the PLL technique is utilized to extract the phase angle of the grid voltages. The PLL is implemented in dq synchronous reference frame. This structure needs the coordinate transformation from abc to dq and the lock is realized by setting the reference to zero. A PI controller is used to control the variable. This structure can provide both the frequency of grid as well as the grid voltage angle.

F. SVPWM Modeling

The proposed approach is based on the instantaneous values of the reference voltages of a, b and c phases only and the actual switching times for each inverter leg are deduced directly [6]. The obtained load current is converted from three phase I_{abc} to two phase components I_d and I_q respectively. The two phase currents are then compared with the reference values of the two phase components and the obtained output is again converted back to three phase components. The obtained three phase components are used to obtain the U_α and U_β by using the transformation as stated below [4, 9].

$$U_\alpha = \frac{2}{3} \left(I_a + I_b \cos\left(\frac{2\pi}{3}\right) + I_c \cos\left(\frac{2\pi}{3}\right) \right) \quad (11)$$

$$U_\beta = \frac{2}{3} \left(I_b \sin\left(\frac{2\pi}{3}\right) - I_c \cos\left(\frac{2\pi}{3}\right) \right) \quad (12)$$

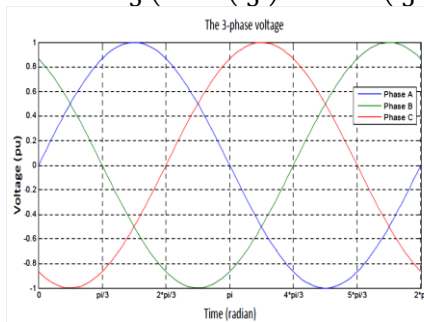

Fig. 3 The sinusoidal wave of three phases

The Figure 3 illustrates the characteristic of sinusoidal waves of a 3-phase system. The period of sinusoidal waves of 3-phase is considered as 6 sectors, which are divided at the critical points of 1.0472 ($\pi/3$), 2.0944 ($2\pi/3$), 3.1416 (π), 4.1888 ($4\pi/3$), 5.236 ($5\pi/3$) and 6.2832 (2π) radians. The blue, green and red lines indicate A – neutral, B – neutral and C – neutral voltages in a 3-phase balanced system. Analysis of the figure reveals the following table [4, 9] (the digit 1 is representative of the corresponding phase amplitude being greater than or equal to 0, the digit 0 expressing the amplitude is less than 0.).

TABLE 1
Sector Selector of PWM

Sector	Areas	Phase A	Phase B	Phase C
1	$0 - \pi/3$	1	1	0
2	$\pi/3 - 2\pi/3$	1	0	0
3	$2\pi/3 - \pi$	1	0	1
4	$\pi - 4\pi/3$	0	0	1
5	$4\pi/3 - 5\pi/3$	0	1	1
6	$5\pi/3 - 2\pi$	0	1	0

For the neutral voltage of Phase A, B and C, in this interpretation of the logical relationship an alternative method of expressing the relationship in algebra, is [7]:

$$N = A + 2B + 4C \quad (13)$$

Where N represents the sector mapping. Based on the above equation the above table can be modified as follows

TABLE 2
Modified Sector Selector of PWM

Sector	Areas	Phase A	Phase B	Phase C	N
1	$0 - \pi/3$	1	1	0	3
2	$\pi/3 - 2\pi/3$	1	0	0	1

3	$2\pi/3 - \pi$	1	0	1	5
4	$\pi - 4\pi/3$	0	0	1	4
5	$4\pi/3 - 5\pi/3$	0	1	1	6
6	$5\pi/3 - 2\pi$	0	1	0	2

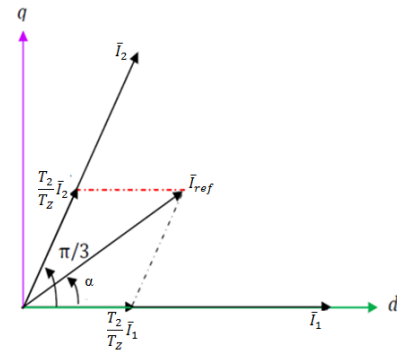

Fig 4 Vector synthesis schematic in sector 1

The Figure 4 illustrates the vectors located in sector, assuming T_z is the unit of time. According to the Figure 4 the time T_1 and T_2 are obtained as follows:

$$\frac{|I_{ref}|}{\sin\left(\frac{2\pi}{3}\right)} = \frac{|I_1|T_1}{\sin\left(\frac{\pi}{3} - \alpha\right)} \quad (14)$$

$$\frac{|I_{ref}|}{\sin\left(\frac{2\pi}{3}\right)} = \frac{|I_2|T_2}{\sin(\alpha)} \quad (15)$$

Simplifying the above equations we get the equations for T_1 , T_2 and T_0 as follows [2],

$$T_1 = \frac{|I_{ref}| \sin\left(\frac{\pi}{3} - \alpha\right)}{|I_1| \sin\left(\frac{2\pi}{3}\right)} = M \sin\left(\frac{\pi}{3} - \alpha\right) \quad (16)$$

$$T_2 = \frac{|I_{ref}| \sin(\alpha)}{|I_1| \sin\left(\frac{2\pi}{3}\right)} = M \sin(\alpha) \quad (17)$$

$$T_0 = T_z - T_1 - T_2 \quad (18)$$

Where M is the ratio of modulation, T_0 is the dead time of the inverter.

$$M = \frac{2 |I_{ref}|}{\sqrt{3} |I_{dc}|} \quad (19)$$

The generated times are the pulse width modulated based on the sector and the time periods obtained based on the following table [8, 12].

TABLE 3
Switching Time Calculation at Each Sector

Sector	Upper Switches (S_1, S_3, S_5)	Lower Switches (S_4, S_6, S_2)
1	$S_1 = T_1 + T_2 + T_0/2$	$S_4 = T_0/2$
	$S_3 = T_2 + T_0/2$	$S_6 = T_1 + T_0/2$
	$S_5 = T_0/2$	$S_2 = T_1 + T_2 + T_0/2$
2	$S_1 = T_1 + T_0/2$	$S_4 = T_2 + T_0/2$
	$S_3 = T_1 + T_2 + T_0/2$	$S_6 = T_0/2$
	$S_5 = T_0/2$	$S_2 = T_1 + T_2 + T_0/2$
3	$S_1 = T_0/2$	$S_4 = T_1 + T_2 + T_0/2$
	$S_3 = T_1 + T_2 + T_0/2$	$S_6 = T_0/2$
	$S_5 = T_2 + T_0/2$	$S_2 = T_1 + T_0/2$

4	$S_1 = T_0/2$	$S_4 = T_1+T_2+T_0/2$
	$S_3 = T_1+T_0/2$	$S_6 = T_2+T_0/2$
	$S_5 = T_1+T_2+T_0/2$	$S_2 = T_0/2$
5	$S_1 = T_2+T_0/2$	$S_4 = T_1+T_0/2$
	$S_3 = T_0/2$	$S_6 = T_1+T_2+T_0/2$
	$S_5 = T_1+T_2+T_0/2$	$S_2 = T_0/2$
6	$S_1 = T_1+T_2+T_0/2$	$S_4 = T_0/2$
	$S_3 = T_0/2$	$S_6 = T_1+T_2+T_0/2$
	$S_5 = T_1+T_0/2$	$S_2 = T_2+T_0/2$

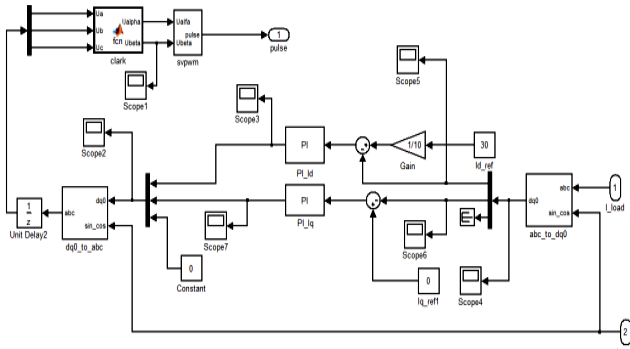

Fig. 5 Simulink Model of SVPWM

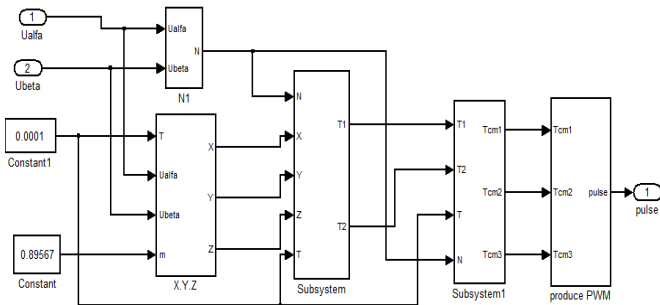

Fig. 5 Simulink Model of SVPWM Subsystem

IV. RESULTS

The output voltage of the proposed Grid connected wind energy with SVPWM control system can be observed as follows.

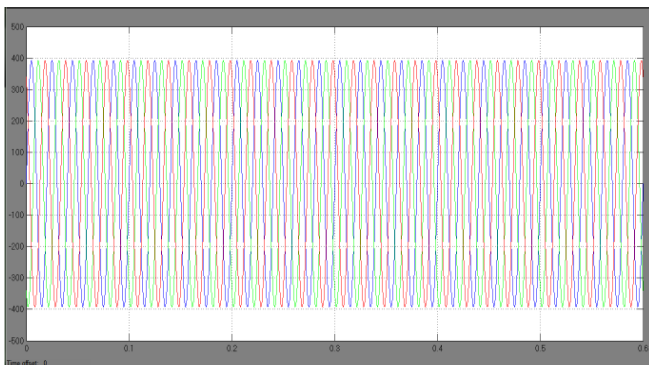

Fig. 6 Output Voltage of the Proposed System vs Time

The output current of the proposed system with SVPWM control can be obtained as follows

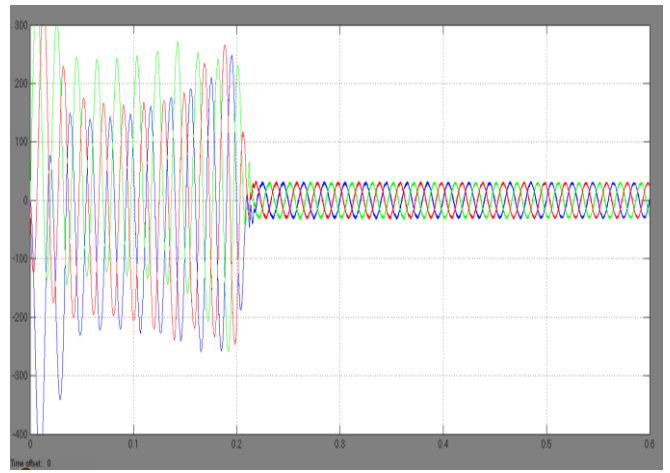

Fig. 7 Output Current of the proposed system vs Time

The pulses generated for the operation of the three leg inverter which is produced from the SVPWM block can be observed as follows

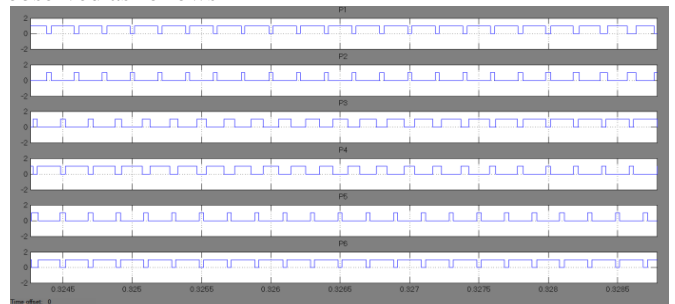

Fig.8 Pulses produced from the SVPWM block

The power variation curve of the wind energy system simulated can be observed as follows

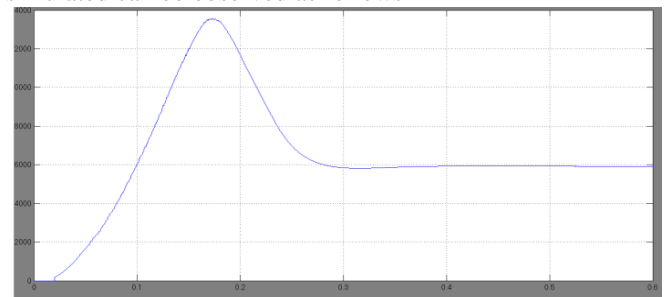

Fig. 9 Variation of Power vs Time for Wind turbine

V. CONCLUSION

The modeling of a wind turbine with a permanent magnet synchronous generator has been treated. The model consists of the wind generator model, an uncontrolled rectifier, an inverter and the inverter control using SVPWM technique. The model has been implemented in MATLAB/Simulink in order to validate it. Power-time characteristics have been obtained.

In future, the model will be extended to the various types of the MPPT algorithms together with different types of converters such as buck/ boost/ buck-boost/ SEPIC converter as well as the various types of wind energy system components.

REFERENCES

1. S. Venkatraj and G. Mohan, "Modeling of Wind Farms with Variable Speed Direct Driven Permanent Magnet Synchronous Generator Wind Turbine" International Journal of Research and Reviews in Electrical and Computer Engineering (IJRRECE), Vol 1, No 3, pp 982-990, September 2011
2. Alejandro Rolan', Alvaro Luna, Gerardo Vazquez, Daniel Aguilar, "Modeling of a Variable Speed Wind Turbine with a Permanent Magnet Synchronous Generator" IEEE International Symposium on Industrial Electronics (ISIE 2009,) July 5-8, 2009, pp 734 – 739
3. K. Vinoth Kumar, Prawin Angel Michael, Joseph P. John and Dr. S. Suresh Kumar " Simulation and Comparison of SPWM and SVPWM Control for three phase inverter" ARPJ Journal of Engineering and Applied Sciences, Vol. 5, No. 7, July 2010, pp 61 – 74
4. D. Sandhya Rani , A.Appaprao, "A Space Vector PWM Scheme for Three level Inverters Based on Two-Level Space Vector PWM" International Journal Of Power System Operation and Energy Management (IIPSOEM) Volume-1, Issue-1, 2011, pp 6 – 10
5. Aryuanto Soetedjo, Abraham Lomi, Widodo Puji Mulayanto, "Modeling of Wind Energy System with MPPT Control" International Conference on Electrical Engineering and Informatics, 17-19 July 2011, E4
6. P.Tripura, Y.S.Kishore Babu, Y.R.Tagor, "Space Vector Pulse Width Modulation Schemes for Two-Level Voltage Source Inverter" ACEEE Int. J. on Control System and Instrumentation, Vol. 02, No. 03, October 2011 pp 34 – 38
7. C. N. Bhende, S. Mishra, Siva Ganesh Malla, "Permanent Magnet Synchronous Generator-Based Standalone Wind Energy Supply System" IEEE Transactions On Sustainable Energy, Vol. 2, No. 4, October 2011, pp 361 – 373
8. Chalasani Hari Krishna, J. Amarnath, and S Kamakshiah, " A Simplified SVPWM Algorithm for Multilevel Inverter Fed DTC of Induction Motor Drive" International Journal of Engineering and Innovative Technology (IJEIT, Volume 1, Issue 4, April 2012, pp 61 – 67
9. C.O. Omeje; D.B. Nnadi; and C.I. Odeh, " Comparative Study of Space Vector Pulse – Width Modulation and Third Harmonic Injected Modulation on Industrial Drives" The Pacific journal of Science and Technology, Volume 13, No 1, May2012, pp 12 - 19
10. Sachin Khajuria, Jaspreet Kaur, " Implementation of pitch Control of Wind Turbine Using Simulink (MATLAB)", International Journal of Advanced Research in Computer Engineering & Technology, Volume 1, Issue 4, June 2012, pp 196 – 200
11. Manoj Kumar Nigam, Ankit Dubey, "Design and Implementation of SVPWM Inverter using Soft Computing" International Journal of Engineering Research & Technology (IJERT) Vol. 1 Issue 7, September – 2012, pp 1 – 5
12. Preeti Soni, Kavita Burse, "Analysis of Voltage Source Inverters Using Space Vector PWM for Induction Motor Drive" IOSR Journal of Electrical and Electronics Engineering (IOSR-JEEE), Volume 2, Issue 6 (Sep-Oct. 2012), PP 14-19.



Sreejith K is a PG scholar pursuing his ME in Power Systems in Government College of Technology, Coimbatore. He has completed his undergraduate in the field of Electrical and Electronics Engineering from Al Ameen Engineering College, Shoranur under the University of Calicut.

AUTHORS PROFILE



Dr. D Mary received her B.E degree in Electrical Engineering from Madurai Kamaraj University, Madurai, Tamil Nadu, India and, the M.E degree in Electrical Engineering from Bharathiar University, Coimbatore, Tamil Nadu, India and her Ph.D. degree in Electrical Engineering Bharathiar University, Coimbatore, India. She is having more than Thirty years of teaching experience in various Government

Engineering Colleges under Directorate of Technical Education, Chennai. Currently, She is working as Professor of Electrical Engineering and Head of the Department of Electronics and Instrumentation Engineering in Government College of Technology, Coimbatore, under Anna University , Chennai, India. Her area of research includes power system, Power Electronics, Intelligent Techniques and Control Systems.



Shinosh Mathew is a PG scholar pursuing his ME in Power Electronics and Drives in Government College of Technology, Coimbatore. He has completed his undergraduate in the field of Electrical and Electronics Engineering from Government Engineering College, Thrissur under the University of Calicut..