

# Off-Grid System Development for House Car Pouch Lighting

S. S. S. Ranjit, S. A. Anas, C. F. Tan

**Abstract**— Practically to electrify lighting system electricity supply is a necessity to power the light. Thus, solar energy is known as an alternative source to provide electricity. This paper presents an off-grid system development for house car porch lighting system. Development of the system is composed of photovoltaic panel, environmental sensors, charge controller, battery and lighting loads such as florescent lamp. The off-grid system focuses to supply electricity in small scale which is integrated with some energy saving characteristics. An auto timer and smart charge controller is integrated into the off-grid system to turn-on and turn-off the lighting at the house car pouch. Integration of some smart functions is an ideal solution for small scale electricity supply or particularly for location which cannot be accessed by grid supply.

**Index Terms**— Off-Grid System, Car Porch Lighting, Florescent Lamp, Timer Controller, Distribution Off-Grid.

## I. INTRODUCTION

Lighting can generally be sourced from an artificial light such as lamps and natural illumination of interiors. Lamps lighting are the major contributor to energy consumption, significantly lighting can be taken into account as part of most energy consumed globally. The performances of the lamps lighting can be enhanced if proper basic handling guidelines are spelled out to educate the consumers, exercising will decrease the abundant and energy wastage of lighting.

For the last decade the electricity consumption in Malaysia is increasing rapidly [1-2]. Research prediction has resulted the demand of electricity consumption will continue to increase over the next decade [2]. As a result, the increasing demand of energy consumption and failing to generate sufficient energy has resulted frequent blackouts [3].

Thus, consumers in Malaysia are always looking to have their homes appliances equipped with energy saving technology. To cater this shortage, technology research enhancement and exploring alternative system or technology is necessary to accommodate the increasing demand of electricity.

### A. House Car Pouch Lighting

Lighting is essential to each corner in this world. Hence, house car pouch also uses lighting to light the car area during the night.

**Manuscript received May 30, 2011.**

**Ranjit Singh Sarban Singh**, Faculty of Electronics and Computer Engineering, Universiti Teknikal Malaysia Melaka, Durian Tunggal, Melaka, Malaysia, +60125541369, (ranjit.singh@utem.edu.my).

**Siti Aisyah Anas**, Faculty of Electronics and Computer Engineering, Universiti Teknikal Malaysia Melaka, Durian Tunggal, Melaka, Malaysia, +60166668517, (aisyah@utem.edu.my).

**Ir. Dr. Tan Chee Fai**, Faculty of Mechanical Engineering, Universiti Teknikal Malaysia Melaka, Durian Tunggal, Melaka, Malaysia, +60122350189, (cheefai@utem.edu.my).

Due to car pouch lighting requirement, many intelligent lighting with motion sensors has been evolved [4]. The sensors intelligently control the lighting and provide security in-conjunction to scare off the intruders. Furthermore, it also provides convenience when the landlord comes back home late in the evening.

**Table 1: Electricity Consumption in Malaysia [2]**

Year	Electricity - consumption	Rank	Percent Change	Date of Information
2003	63,480,000,000	33		2001
2004	68,400,000,000	34	7.75 %	2002
2005	68,400,000,000	33	0.00 %	2002
2006	73,630,000,000	33	7.65 %	2003
2007	72,710,000,000	34	-1.25 %	2004
2008	95,980,000,000	30	32.00 %	2006 est.
2009	95,980,000,000	30	0.00 %	2006 est.
2010	99,250,000,000	29	3.41 %	2007 est.

Conventionally, car pouch lightings are manually controlled with the control switch which is connected to the home electrical network. In other words, the car pouch lighting uses the grid network system which is not independent and outage of electricity will be the disadvantage to the system while living the car park or pouch with no light.

Off-grid system development attributes to the existing car pouch lighting system. This paper describe about the development of an Off-Grid House Car Pouch Lighting System based on the Photovoltaic Technology (PVT). The system development consists of photovoltaic panel, sensor, charge controller, battery and lighting as load. PVT explains the system applies full and consumes supply from a non-grid connected system. The PVT system converts the sun light rays into electricity to electrically energize the non-grid connected system.

This system automatically control the light switching, thereby achieving and improving the efficiency while limiting the human effort to operate the system. Even though it limits the human effort but the system maintenance still requires the human intelligence.

Non-grid connected system plausible to reduce the installation cost for the grid connection electrical network. Additionally, the non-grid connected system provides low cost operating power due to using the renewable energy, abundant and largely unlimited energy source such as solar energy available in the Asian region including Malaysia.



## II. LITERATURE REVIEW

### A. Off-Grid Power Systems

Stanislav Misak and Lukas Prokop [5] described that the off-grid power systems operates independently. These systems are often used as main power sources for places with unavailability of grid connection. The availability of many renewable sources creates an opportunity for individual and industries to develop off-grid power systems such as wind power plants, photovoltaic systems, diesel generators, small water plants, bio-gas generators and fuel cells. To develop an off-grid power system, analysis of geographic and meteorological conditions of a particular location is an important factor to develop the off-grid power system. Basically the development of an off-grid power system can be solely based on solar and wind or combination of both solar and wind which result a unit called hybrid system. The analysis result of meteorological study is to determine the most suitable combination of a system development [5].

### B. Intelligent Control System

Multi sensors are combination of sense environment and digital system is to create a logical control system. These sensors are integrated in such an intelligent methodology to control the street lighting intelligently. Involvement of optical-control attributes to the second generation of street lighting control system. The time-controlling method assists the system time for opening and closing the street lightings. It also provides the time to time control based on the time-optical control method which has the feedback via the light intensity control. This type of system is integrated between hardware and software can be controlled using a personal computer.

### C. Solar Power as an Alternative Source of Electrical Energy

Solomon Nunoo, Joseph C. Attachie and Charles K. Abraham outlined off-grid source is an alternative source to electrify the street lighting [6]. Existing street lighting integrates discharge lamps which drawbacks cause high power consumption, low efficiency, fragile and low rated life [7]. Their studies described, a basic charge controller basis photovoltaic system preserves the electricity energy into the battery storage during the sunny day. Then the preserved energy is utilized to power the street lighting.

In their designed system, the battery power is regulated to 12 VDC. The DC to DC battery charger converts the solar energy into electricity using the buck topology concept and stores the electricity in the battery storage. The over voltage, under voltage and reserve-connection protection is taken into consideration to protect the battery storage and the street lighting.

### D. Multi-Sensor Array

Wu Yue, Shi Chanhong and Yang Wei outline the acquisition streetlights background signal by multi-sensor. Sound, light, infrared, vibration and etc are the multi-sensor arrays that are use to get the street lights environmental information. The combination with variety of clock control strategy for control lamps, it can achieve the background information of perception, detection, identification, and collect the typical characteristics of an effective signal, to rationally determine the threshold value range in the circuit

design and lay a solid foundation for the realization of intelligent control of lights [8].

They discussed the experiment principle of multi-sensor. According to them, the vibration sensor is a sort of device which can change the ground surface shake caused by mobile into electrical signal. The infrared wave variation of mobile to electrical signal can be changed by referring to the principle of pyroelectricity infrared sensor.

Wu Yue, Shi Chanhong and Yang Wei give a very brief explanation on the experimental program of multi-sensor array. Experimental includes separate tests then combine the sensors to collective signals. The sensor array is tested by starting with indoor background or foreign environmental background noise performance testing laboratories. The collection of experiment is carrying out separately for signals of the staff and vehicles.

### E. Infrared Pyroelectric Sensor

Tarik M. Hussain, Ahsen M. Baig, Tarek N. Saadawi and Samir A. Ahmed give an overview of infrared pyroelectric sensor for detection of vehicular traffic using digital signal processing technique. Pyroelectric detectors convert incident thermal infrared optical power that is received to an electrical output signal [9]. It provides sufficiently high output signals to permit an easy interface with a measurement or control circuit [10].

They outline pertaining to pyroelectric detectors which are known as crystal devices. They are used to measure radiant energy over a wide spectral range. Pyroelectric detectors can respond to thermal infrared radiation.

Basic elements of the system consist of two passive pyroelectric detectors S1 and S2 where each pyroelectric sensor consist of a semiconductor sensing element and integral built in electronics. According to them, the monitoring system using infrared pyroelectric detectors is designed to be low maintenance and easy to be installed. A vehicle detection system has to be reliable and need to have sufficient sensitivity so that the signal-to-noise ratios are sufficiently high for reliable operation.

These guys outline the effects of vehicle passage on received signals. From the experiments, the signal received from a truck has wider pulse widths due to the truck's length and hence longer time under the field of view of the sensor.

The results of the demonstrations indicate that the developed system technology shows of being practical and cost-effective.

## III. EXISTING PRODUCTS

### A. Motion Sensor Light Control

This Motion Sensor Light Control is an automatic lights control which is one of the easiest ways to improve the home security.

This product can turn an existing light into a motion light quickly. The Motion Light adapter is screwed into the existing lamp and the sensor is mounted to the wall. When motion is detected, the light will automatically turn on [11]. It is an ideal for driveways, car porch or any places that are convenient for lighting. The sensor comes equipped with two adjustable settings which are day and night or night only.

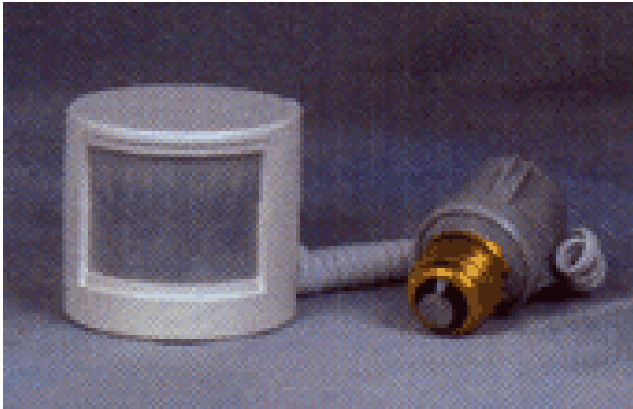

Figure 1: Motion Sensor Light Control

The main features for this product are it turns existing light into a motion light, easy to install, able to control up to 150 W per socket, provides adjustable settings for one to 10 minutes, can detect up to 50 meters range with 120 degree detection arc and the device comes with optional Add-On Socket Adapter available for a dual spotlight.

However, there are still disadvantages of this product as compared with the design of developed off-grid system for house car porch lighting. The Motion Light Control uses time-control method in order to control the light opening and closing time, but the maximum timer switch allows is only 10 minutes and after that the light will turn off if there is no motion detected. This is not reliable for some owners that want the lights to turn on for longer time period. Unlike for the developed off-grid system for house car porch lighting that can set the time to light up for more than an hour.

Another major disadvantage as compared with the design of the developed off-grid system for house car porch lighting is that the device uses grid power connection which is not independent and seems to be high energy consumption. Where else, the off-grid system for house car porch that works on independently basis is more reliable, independent and cost-effective.

### B. Porch Lighting Home Automation Kit

This Porch Lighting Kit able to light up the porch lights just by clicking remote keychain-like (shown in Figure 3). This remote porch lighting solution is very handy and the remote is the main controller of the lighting system. The lighting system uses socket lamp module (shown in Figure 2), where it requires only to screw them into any standard light socket, screw in the light bulb in order to control the lights with the remote.

This device operates by the use of transceiver (shown in Figure 4) which is the key to any home automation system. The transceiver receives the signals from remote and commands the relays through the home's existing wiring to the porch lights.

Since it is wireless house car porch lighting system, the time consumes to set up this system only takes at about five minutes and moreover it requires no tools. The main features of this device are obvious where it controls porch light by handy remote, the remote works from up to 100 feet away through anything and transceiver doubles as a lamp/appliance module for control of an additional light. Moreover, the system is easy to set up.

Even though this product looks very simple and sophisticated, but still it can cause energy wastage. This is

clear when operating porch lighting home automation kit requires transceiver to be always in condition and always get power supplied by the grid power. Plus, this product works dependently with the on-grid power which it unable to operate if there is a blackout situation happened. Moreover, the product controls the car porch lights by the use of handy remote control which uses human power. It seems to be difficult to switch on the lights when the owner is located more than 100 feet away from the house. During night, it cannot automatically switch on the house car porch lights. Unlike the off-grid system for house car porch lighting which operates independently by the use of an off-grid system which uses PV system to automatically switch on the car porch light once the surrounding place getting dark.

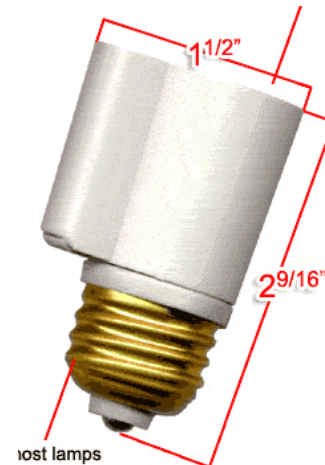

Figure 2: Socket Lamp Module



Figure 3: Keychain Remote





Figure 4: Transceiver

**C. Solar Security Floodlight with Motion Sensor**

This is the ultimate design of security light that ever exists in the market nowadays. The solar floodlight provides security for home and cost effective. The device consists of motion sensor that turns on the device automatically when movement detected, creating an area of instant light when people walks up to the home or during more vulnerable time when a potential thief comes snooping.

This dependable floodlight able to detects motion within 180 degrees and up to 35 feet away. It is said that this device is easy to install where it requires no wires, no electricity and no operational cost. Once activated by motion, the time duration for when the floodlight is on can be set from 10 seconds to 1 minute. When charged with full sunlight, the solar floodlight can work up to 150 times when on for 60 seconds at a time. In addition, the unit features motion sensitivity.



Figure 5: Solar Security Floodlight with Motion Sensor

The floodlight kit includes an adjustable swivel head and sensor, equipped with 15 foot cable, 10 watts halogen bulb which is more efficient than incandescent light bulb. It runs on a 6 Volt 4 Ampere acid rechargeable battery.

This sophisticated product is only reliable for home security where the floodlight is on once activated by motion. Whereby, off-grid system for house car porch is reliable not only for home security but also extend the service life of lighting equipment which it involves time-control method that is, from time to time opening and closing control.

**IV. RESEARCH METHODOLOGY**

**A. Solar Radiation**

The off-grid system for house car porch lighting requires solar energy in order to operate independently, the location of the house must be at the area which have sufficient sunlight ray source. Thus, it is important to determine the amount of

electricity produce by photovoltaic cells by calculating the average daily solar radiation that hits on the photovoltaic cells. Table 2 shows the average daily solar radiation in Malaysia region as calculated by using HOMER software. Based on the extracted data, in average Malaysia is blessed with 4.947 KiloWatt/Hour/m<sup>2</sup>/day. This number is very much sufficient to supply electricity to a modest home powering all the necessary basic equipment, such as lighting, fan and some of the electrical devices.

**Table 2: Average Daily Radiation in Malaysia**

Month	Clearness	Daily Radiation
	Index	(kWh/m <sup>2</sup> /d)
January	0.502	4.933
February	0.531	5.434
March	0.517	5.412
April	0.498	5.133
May	0.478	4.703
June	0.498	4.747
July	0.489	4.718
August	0.483	4.855
September	0.480	4.961
October	0.494	5.059
November	0.472	4.661
December	0.496	4.791
<b>Average</b>	<b>0.495</b>	<b>4.947</b>

**B. Battery Size**

The system uses lead acid battery which is use to handle the simultaneous charging and discharging that occurs with the day to day variations in sunlight [12]. The calculation to determine the battery size is as described:

Days of energy storage = 7 Days  
 Allowable depth discharge = 0.8  
 Required battery capacity = (32Ah × 7 days) ÷ 0.8 = 280Ah  
 Selected battery rating = 300Ah  
 Number of battery in parallel = 280 ÷ 300 = 0.93 ≈ 1 battery  
 Number of battery in series = 12V ÷ 12V = 1 battery  
 Total number of battery = 1 × 1 = 1 battery  
 Total amp-hours of battery = 1 × 300Ah = 300Ah  
 Total battery kilowatt-hour capacity = (300Ah × 12V) ÷ 1000 = 3.6kWh

**C. Photovoltaic Array Size**

Originally, the photovoltaic panel uses photoelectric cells that convert light into electricity. It is made up like sandwich which consists of silicon containing special chemicals [13]. There are two types of semiconductors which are N-type (in which there are a lot of nearly free electrons) and P-type (in which there are a lot of holes) [14].

The calculation for determining photovoltaic array size is shown below:

Total demand energy per day = 192 Watt/day  
 Required array output per day = 192 ÷ 0.85 = 225.88Watt/hour

#### D. Charge Controller

Charge controller regulates the electricity flow from the generation source before entering to the battery load [15]. Charge controller has been regarded as one of the important devices in off-grid photovoltaic systems to prevent the battery from damage due to over-charging and over-discharging [16]. The charge controller keeps the battery fully charged without over-charging it. When there is a power load, the charge controller allows the charge to flow from the photovoltaic panel into the battery and finally to the off-grid system. When the charge controller senses that the battery is fully charged or nearly full, it reduces or stops the flow of electricity from the solar panel source to the battery [17].

#### V. SYSTEM DEVELOPMENT

This off-grid system for house car porch lighting uses the photovoltaic technology (PVT) concept. The system composed of photovoltaic array or photovoltaic panel, sensors, charge controller, battery and lighting loads such as florescent lamp.

This system is designed to achieve 10 W halogen lamp drivers. During the daytime the controller preserves the electricity energy gathered by the solar panel, and then stores the energy in the 12 Volt lead acid batteries. Whereby, in the evening the charge controller uses the battery energy to power the light bulb.

The system block diagram is illustrated in Figure 7. Sun ray delivers rays of photons or also known as solar energy which hit the photovoltaic panel. This solar panel converts the sunlight ray into electricity. This conversion happens when the sunlight strikes the silicon plates of the solar panel, freeing charged electrons and bumping them into energy field [12]. The electrons are able to move in one direction and this can give the electrons somewhere to go [13]. Energy is stored in the battery during daytime and consumed at night. The lamp (car porch lamp) is driven to operate by the controller that monitors the system and manages the light on and light-off in day and night time.

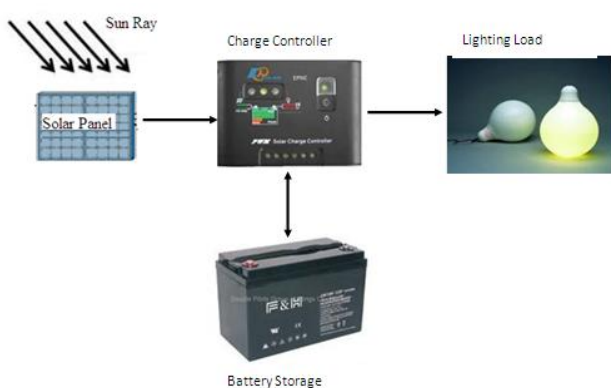

Figure 7: Off-Grid System for House Car Porch Block Diagram

#### VI. DISCUSSION

This paper discuss on the development of off-grid system for house car porch lighting. The system composed of photovoltaic array or photovoltaic panel, sensor, charge controller, battery and lighting loads such as 10 Watt halogen lamp. This paper also discusses the use of solar power as an

alternative source to supply electrical energy that is practical for house car porch lighting in Malaysia. It proposes the use of lighting systems that receive energy from lead-acid batteries, charged by the solar panels. The design has an auto turn-on and turn-off for the house car porch lights. The system is designed with a smart controller where it allows car porch lamp automatically lit in the evening, lighting the porch for a few hours with the time adjustable.

#### VII. CONCLUSION

Off-grid lighting system has addressed many advantages when it comes to the environment control, energy saving, safety control and many others application. Based on the study, developing this kind of system can indirectly contribute into environmental control and energy saving characteristics. Apart from that, integrating this kind of stand-alone system into a small application like house car porch lighting could help the owner or the resident to have light throughout all the night without paying any extra dollars.

#### VIII. RESULTS

An off-grid system for house car porch lighting is designed to achieve electrical energy saving. It able to operate independently by the use of PVT system that uses solar energy to generates electricity. Furthermore, this technology can works automatically by the use of smart charge controller. When the day becomes dark, it automatically light up the car porch light and the light will off after a few hours (depends on set time). During dark, it will automatically turn the light on, once motion is detected by the sensor. Thus, the system helps to save the electrical energy consumption.

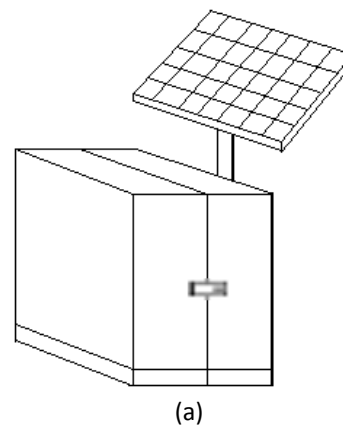

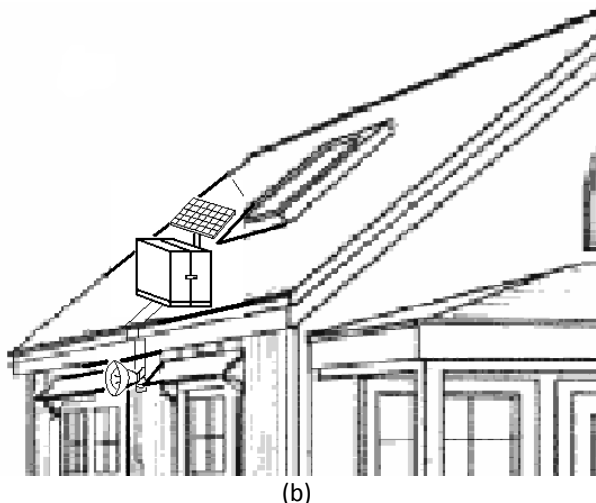

**Figure 8 (a) Off-Grid Sensing System for House Car Pouch, (b) System Attached to Personal House**

### ACKNOWLEDGMENT

Funding for this project is provided by the Short Term Research Grant Scheme (STRG), Universiti Teknikal Malaysia Melaka, Malaysia. This research has been conducted at Universiti Teknikal Malaysia Melaka. We would like to express our gratitude to the Universiti Teknikal Malaysia Melaka and Malaysian Government for the grant and Universiti Teknikal Malaysia Melaka for the support given during the research.

### REFERENCES

1. H.P Garg, J. Prakash, "Advances in Solar Technology", vol. III. New Delhi: Tata McGraw-Hill, 2002, pp. 402-411.
2. [http://www.indexmundi.com/malaysia/electricity\\_consumption.html](http://www.indexmundi.com/malaysia/electricity_consumption.html). 1.30pm, 19 December 2010
3. J. A. Aboagye, "An Alternative Street Lighting for UMAT Campus using LED (Light Emitting Diode) Lamps", *BSc Project Work*, University of Mines and Technology, Tarkwa, May 2010.
4. Wu Yue, Shi Changhong, Zhang Xianghong, Yang Wei, "Design of New Intelligent Street Light Control System", 2010 8th IEEE International Conference on Control and Automation Xiamen, China, 21 December 2010.
5. Stanislav Misak, Lucas Prokop, "Off-Grid Power Systems", Technical University of Ostrava, Faculty of Electrical Engineering and Computer Science, Department of Electric Power Engineering, Ostrava, Czech Republic. 20<sup>th</sup> December 2010.
- 6.
7. Solomon Nunoo, Joseph C. Attachie and Charles K. Abraham, "Using Solar Power as an Alternative Source of Electrical Energy for Street Lighting in Ghana", Department of Electrical and Electronic Engineering, University of Mines Technology, Western Region, Ghana, 19 December 2010.
8. Anon., "Types of Lamps Used in Streetlights", retrieved on February 10, 2010 from <http://www.eskimo.com/~jrterry/lamps.html>. 19 December 2010
9. Wu Yue, Shi Changhong, Yang Wei, "Study Of Acquisition Streetlights Background Signal By Multi-Sensor Array", International Conference on Control, Automation and Systems 2010, 21 December 2010.
10. Tarik M. Hussain, Ahsen M. Baig, Tarek N. Saadawi, Samir A. Ahmed, "Infrared Pyroelectric Sensor for Detection of Vehicular Traffic Using Digital Signal Processing Technique", IEEE Transactions On Vehicular Technology, 23 December 2010.
11. W. J. Mooney, "*Optical Devices and Principles*". Englewood Cliffs, NJ: Prentice Hall, 1991, 20 December 2010.
12. <http://www.carlonchimes.us/ccus-lighting-controls-motion-activated.htm>, 11.25 a.m, 23 December 2010
13. K. Jardin and Istvan Nagy, "Modeling of a Combined Photovoltaic / Thermal Energy System", Procs. of Power Electronics and Motion Control Conference, pp. 1754, 24 December 2010.

14. [en.wikipedia.org/wiki/Solar\\_cell](http://en.wikipedia.org/wiki/Solar_cell), 21:53 p.m, 24 December 2010
15. NowshadAmin, Lam Zi Yi and Kamaruzzaman Sopian, "Microcontroller Based Smart Charge Controller For Stand-Alone Solar Photovoltaic Power Systems", Procs. of IEEE Photovoltaic Specialists Conference (PVSC), pp. 1094, 7-12 June 2009.
16. [solar-batteries.net/](http://solar-batteries.net/), 1:10 a.m, 24 December 2010.

### AUTHORS PROFILE



**Ranjit Singh Sarban Singh** was born on 30 April 1982. He received his Diploma of Technology Computer (Electronics Engineering) from Politeknik Seberang Perai, Malaysia in 2003. He then graduated with a Bachelor Degree in Electronics Engineering (Computer Engineering) from KUTKM Malaysia in 2006 and received his Master of Science Engineering from Multimedia University, Melaka Malaysia. His keen interest is in image processing motion estimation, solar system application and electronics applications. Besides that, the author is involved in the development of motion estimation algorithm application, actively involved in smart consumer electronics applications and design and development solar systems.



**Siti Aisyah binti Anas** was born on 17 May 1985. She received her Bachelor of Electronics Engineering (Computer Engineering) from Universiti Teknikal Malaysia, Melaka in 2008. The author then remains in the same university and begin her career as a tutor. In 2010, she graduated with Master in Communication and Computer Engineering from Universiti Kebangsaan Malaysia. Currently she serve as a lecturer at Universiti Teknikal Malaysia Melaka. Her fields of interest are mainly focusing on software development, programming in C/C++ and embedded microcontroller programming. Besides that, she also involving in developing product based on electronics applications. Siti Aisyah has been actively involved in numerous competitions and exhibition for the past several years in both local and international events whereby she have won bronze medal in MTE 2009, silver medal in ITEX 2009, gold medal in Brussels Innova 2009 and bronze medal in MTE 2011 and ITEX 2011.



**Ir. Dr. Tan Chee Fai** graduated in Mechanical Engineering with honours, Master of Science in Manufacturing Systems Engineering from Universiti Putra Malaysia and PhD in Industrial Design Engineering from Eindhoven University of Technology, The Netherlands. He is a Senior Lecturer at Department of Design & Innovation, Faculty of Mechanical Engineering, Universiti Teknikal Malaysia Melaka since 2003. He actively involved in teaching and learning, consultation as well as research and development activities. Ir. Dr. Tan has published over 80 papers in referred conferences, book chapter and journals. His research interests cover the aspects of mechanical engineering design, industrial design, smart system, multidisciplinary design and human-technology interaction design.