

# Compact Zigzag Inverted-F Antenna with Matching Network for Wi-Fi Operation in Portable Devices

Md. Selim Hossain, Debabrata Kumar Karmokar, Khaled Mahbub Morshed

**Abstract**— This paper presents a compact zigzag inverted-F antenna with matching network for Wi-Fi operation in portable devices. The antenna occupies a very small area of  $8 \times 18 \text{ mm}^2$  and provides high gain of 6.91 dBi with the peak return loss of -49.75 dB, VSWR of 1.006 and input impedance of 50.2045  $\Omega$  at 5.5 GHz. This antenna covers a 10 dB return loss bandwidth of 609 MHz (5250 MHz~5859 MHz). In addition an impedance matching pie filter is used to ensure impedance matching between the source and the antenna. As well, the antenna has acceptable radiation characteristics.

**Index Terms**— Inverted-F antenna (IFA), Compact Antenna, Matching Network (MN), Zigzag IFA, Voltage Standing Wave Ratio (VSWR), Wi-Fi.

## I. INTRODUCTION

Recently the swift growth in wireless communication system leads to several growing demands with the designing of various portable devices require small, low profile and multi-function antenna. In order to satisfy these demands, inverted-F antenna (IFA) has been widely used in portable devices due to its compact, low profile configuration, ease of fabrication and favorable electrical performance. The wireless fidelity (Wi-Fi) operates in the 2.4 GHz band (2.4–2.484 GHz) and 5 GHz band (5.15–5.35 GHz, 5.47–5.725 GHz, and 5.725–5.875 GHz) [1–3].

A T-shaped monopole antenna with dual shorted L-shaped strip-sleeves for dual operating band with bandwidth of 834 MHz (1962~2796 MHz) and 576 MHz (5328~5904 MHz) at lower and upper frequency bands respectively [2], a internal composite monopole antenna for WLAN/WiMAX operation in a laptop computer covers triple operating bandwidth of 347 MHz (2371~2718 MHz), 600 MHz (3192~3792 MHz) and 841 MHz (5051~5892 MHz) at lower, middle and upper frequency band respectively [3], a modified two-strip monopole antenna for Wi-Fi and WiMAX applications [4],

**Manuscript Received October 30, 2011.**

**Md. Selim Hossain** is with the department of Electrical & Electronic Engineering, Khulna University of Engineering & Technology (KUET), Khulna-9203, Bangladesh. E-mail: selimkueteer@yahoo.com

**Debabrata Kumar Karmokar** is with the department of Electrical & Electronic Engineering, Khulna University of Engineering & Technology (KUET), Khulna-9203, Bangladesh. E-mail: debeee\_kuet@yahoo.com

**Khaled Mahbub Morshed** is with the department of Electronics & Communication Engineering, Khulna University of Engineering & Technology (KUET), Khulna-9203, Bangladesh. E-mail: kmm\_ece@yahoo.com

internal wideband metal-plate antenna for laptop application covers a wider bandwidth of 3.9 GHz (2.1~6.0 GHz) [5], dual band flat plate antenna with shorted parasitic element for laptop applications with impedance bandwidth of 190 MHz (2330~2520 MHz, centered at 2.4 GHz) and 2140 MHz (4520~6660 MHz, centered at 5.5 GHz) for the 2.4 and 5.8 GHz WLAN band [6], internal PIFAs for UMTS/WLAN/WiMAX multi-Network operation for a USB dongle [7], uni-planer dual band monopole antenna for 2.4/5 GHz WLAN operation in a laptop computer [8], dual wideband printed monopole antenna for WLAN/ WiMAX applications [9] respectively have been proposed.

To provide the increasing demand and cover up the widespread applications of 5 GHz band (5.15–5.35 GHz, 5.47–5.725 GHz, and 5.725–5.875 GHz) for Wi-Fi operation a low profile antenna with wider bandwidth, high gain and less gain variation within the antenna bandwidth is desired. To meet up most of the mentioned requirements, the proposed zigzag inverted-F antenna is one of the good candidates within the micro-strip printed antennas because of its compact size and good input impedance than other printed antennas.

In this article, we present a promising low profile antenna named zigzag inverted-F antenna (zigzag IFA) for 5.5 GHz Wi-Fi operations in a laptop computer.

## II. ANTENNA GEOMETRY

In designing the low profile antenna for Wi-Fi operation in a laptop, we examine the possibility of increasing antenna bandwidth, gain and maintaining the input impedance near about 50  $\Omega$  by using impedance matching network throughout the application bands with simplifying its structure using method of moments (MoM's) in Numerical Electromagnetic Code [10]. The cost of FR4 substrate is higher than the RT/duroid 5880. For the lower cost, in numerical analysis we considered the substrate permittivity of the antenna is  $\epsilon_r = 2.2$  (RT/duroid 5880) with substrate thickness of 1.58 mm. Our attempt was to reduce the size of the antenna with improved gain for the 5.5 GHz Wi-Fi operation in a laptop computer.

The antenna is assumed to be feed by a 50  $\Omega$  coaxial cable, with its central conductor connected to the feeding point and its outer conductor connected to the ground plane. For impedance matching, we use pie type matching network. Fig. 1 (a) and 2 (b) show the inverted -F antenna 3-D and 2-D view (structure 1).

Fig. 2 (a) and (b) show the structure of zigzag IFA 3-D and 2-D view (structure 2) (proposed). Here one leg of zigzag IFA directly connected to the feeding and another leg spaced  $s$  from the ground plane. In the analysis the dimensions of the ground plane considered as  $60\text{ mm} \times 60\text{ mm}$ . Fig. 3 (a) and (b) represent the modified zigzag inverted-F antenna 3-D and 2-D view (structure 3).

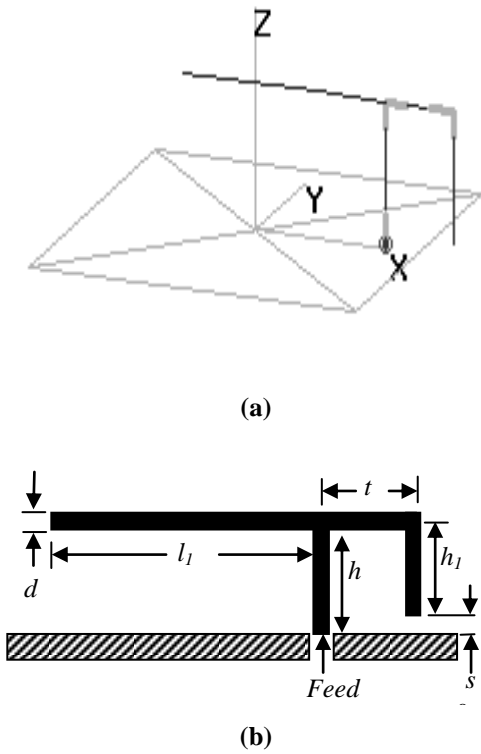

Fig. 1. Inverted-F antenna (Structure 1) (a) 3-D and (b) 2-D view

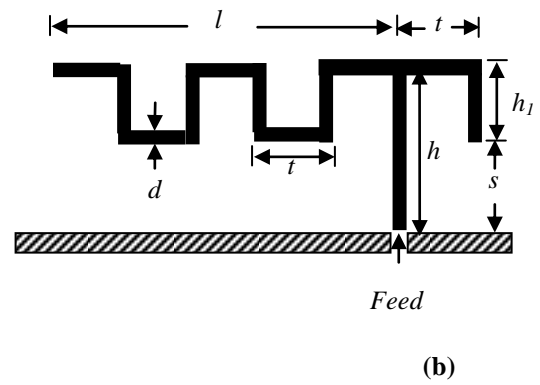
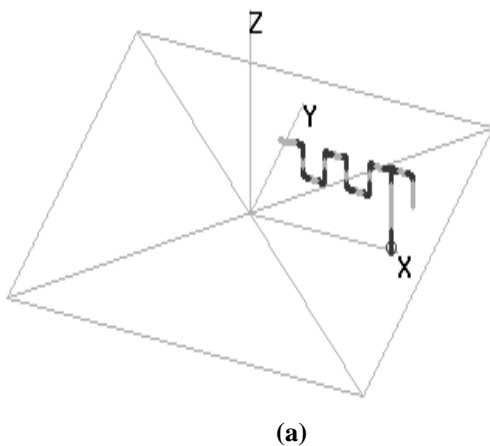

Fig. 2. Zigzag inverted-F antenna (Structure 2) (a) 3-D and (b) 2-D view (Proposed)

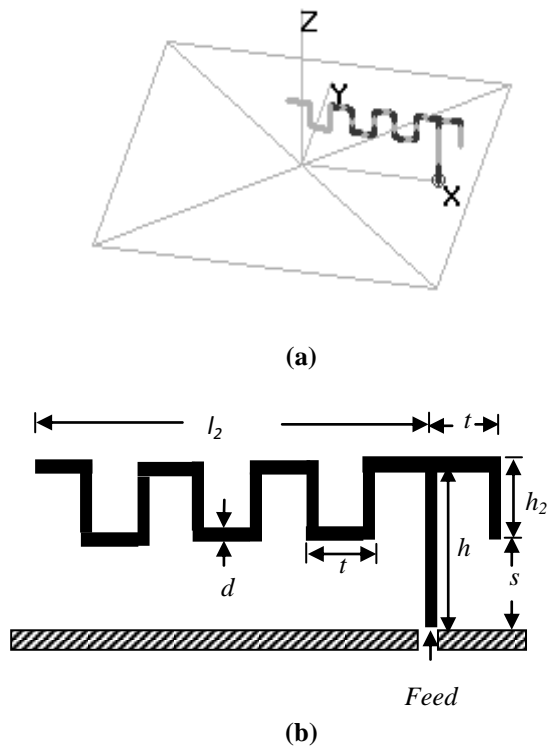

Fig. 3. Modified Zigzag inverted-F antenna (Structure 3) (a) 3-D and (b) 2-D view

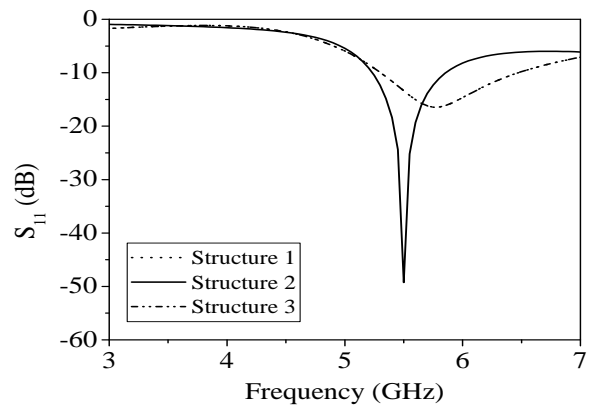

Fig. 4. Variation of return loss (dB) for different antennas (structure) with frequency

Fig. 4 represents the return loss variation of different antennas. From this figure, the structure 2 shows the best performance. Fig. 5 (a) represents the variation of return loss for different values of  $h_1$  of zigzag IFA. From the analysis on fig. 5 (a) for the optimized value of  $h_1$ , we see that when the value of  $h_1=4$  mm, the antenna provides maximum return loss but gain reduces remarkably at the operating band as shown in Fig. 5 (b). The return loss and gain variation for different values of  $t$  are shown in Fig. 6 (a) and (b) respectively. For the value of  $t=4$  mm, the antenna provides high return loss but gain is very low for the required band. Besides the values of  $t=2$  mm and  $t=4$  mm does not cover the required 5.5 GHz band. Besides when the value of  $t=3$  mm, the antenna fully covers the 5.5 GHz band for Wi-Fi operation in a laptop computer.

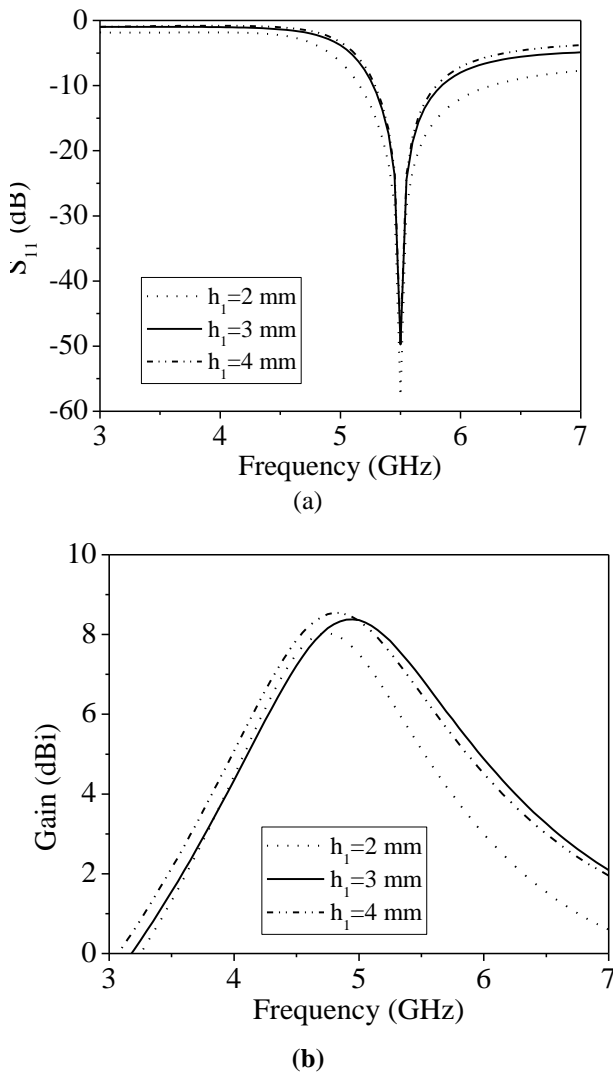

Fig. 5. Variation of (a) return loss (dB) and (b) gain of different values of  $h_1$  of zigzag IFA

Table I represents the optimized dimensions of the proposed antenna of Fig. 1. From table I, we see that the dimension of proposed antenna is  $8 \times 18$  mm<sup>2</sup>. Fig. 7 represents the matching network for zigzag inverted-F antenna for impedance matching. We use pie type matching network for zigzag inverted-F antenna. From Fig. 4 we see that  $X_{p1}$  and  $X_{p2}$  are the parallel capacitor and  $X_s$  represent series inductor whose value given in the table II. Table II

represents the matching network parameters of the proposed zigzag inverted-F antenna.

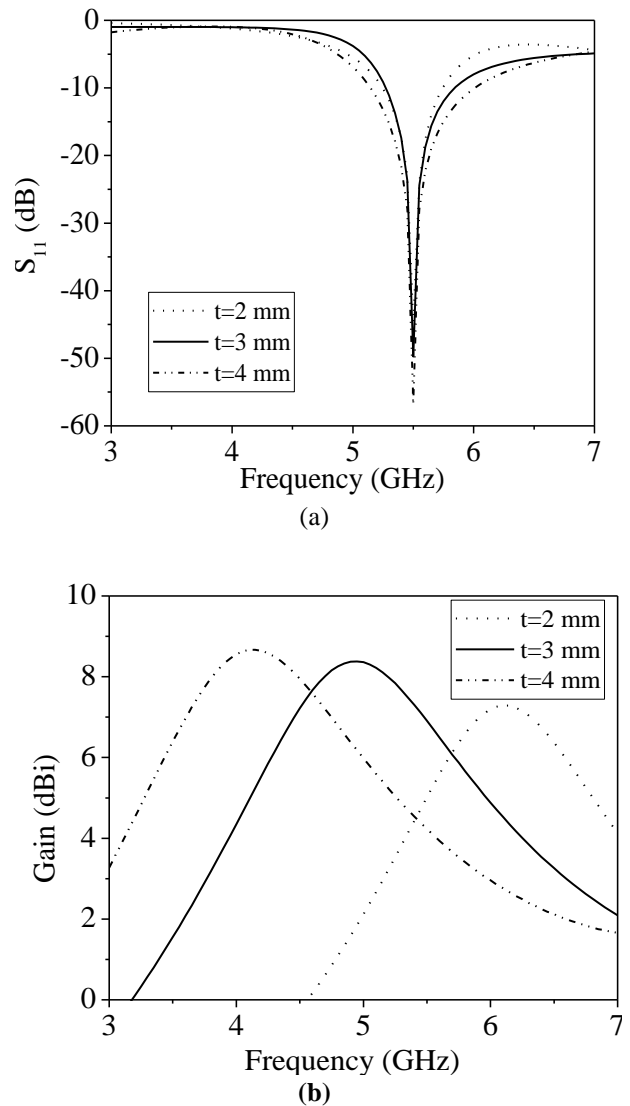

Fig. 6. Variation of (a) return loss (dB) and (b) gain for different values of  $t$  of zigzag IFA

TABLE I. DIMENSION OF THE PROPOSED ZIGZAG INVERTED-F ANTENNA

Antenna name	Antenna parameters	Values (mm)	Dimension (mm <sup>2</sup> )
Zigzag IFA	$l$	15	$8 \times 18$
	$t$	3	
	$l+t$	18	
	$h$	8	
	$h_1$	3	
	$d$	2	
	$s$	5	

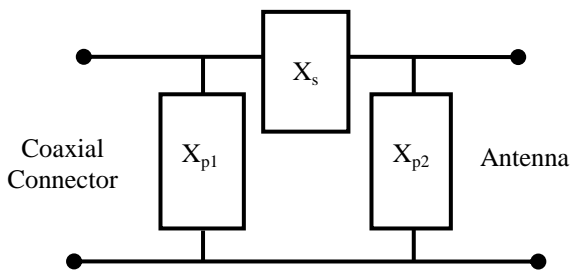

Fig. 7. Matching network (MN) for zigzag IFA

TABLE II. MATCHING NETWORK PARAMETERS OF THE PROPOSED ZIGZAG INVERTED-F ANTENNA

Network parameters	Value
$X_{p1}$	0.25 pF
$X_{p2}$	0 pF
$X_s$	2.02 nH

III. NUMERICAL SIMULATION RESULTS

The simulated return losses of the proposed zigzag IFA with and without matching network (MN) are shown in Fig. 8. From the simulation results, the zigzag IFA has return loss bandwidth of 609 MHz (5250~5859 MHz) and 1150 MHz (5750~6900 MHz) with and without MN respectively. From the simulation result we see that the zigzag IFA without matching network covers a wider impedance bandwidth than the antenna with matching network. But the impedance bandwidth without matching network covers extremely little portion of the required operating band. On the other hand, with matching network the antenna covers almost all portions of the 5.5 GHz Wi-Fi operating band with the peak value of the return loss is -49.75dB.

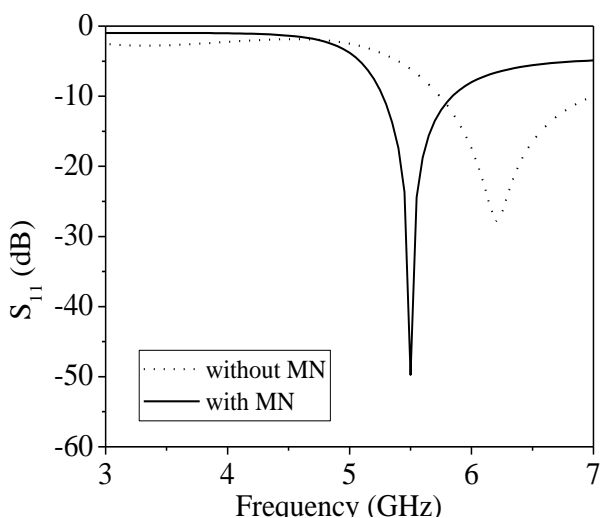

Fig. 8. Return loss (dB) variation of zigzag IFA with frequency

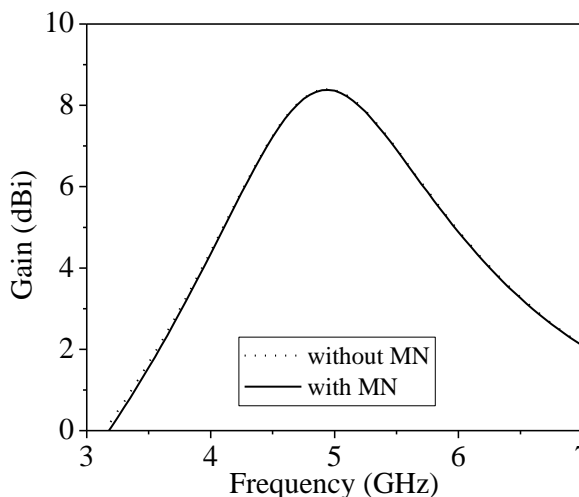

Fig. 9. Gain (dB) variation of zigzag IFA with frequency

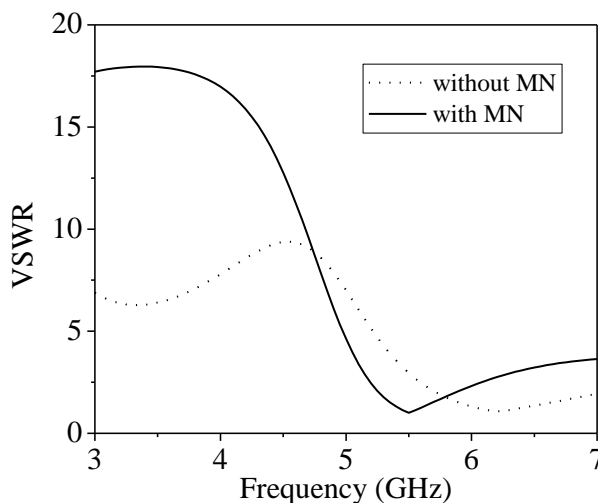

Fig. 10. VSWR variation of zigzag IFA with frequency

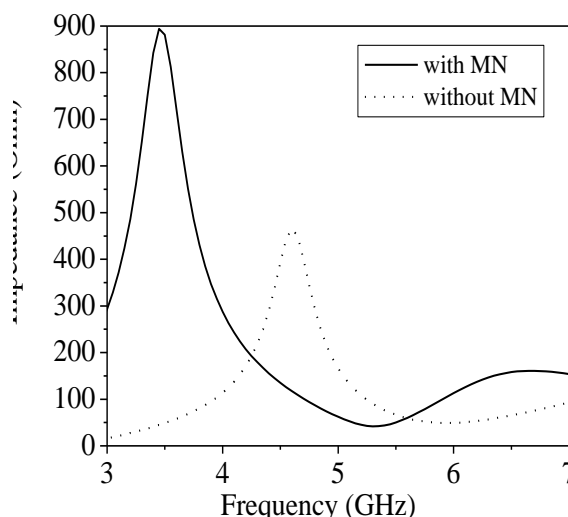
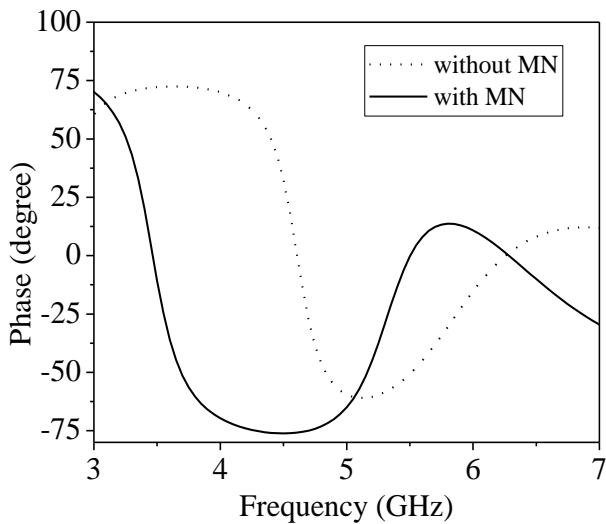

Fig. 11. Impedance (ohm) variation of zigzag IFA with frequency

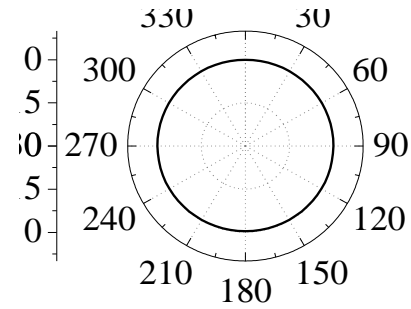

**Fig. 12. Phase (degree) variation of zigzag IFA with frequency**

The gain variation of the zigzag IFA as a function of frequency is shown in Fig. 9. From the obtained results, antennas gain varies from 7.84 to 5.46 dBi at within the 10 dB return loss. The value of VSWR of zigzag IFA is 1.006 at 5.5 GHz. So, the obtained result indicates that the value of VSWR is very low and it is near to 1 as shown in Fig. 10. Fig. 11 represents the antenna input impedance variation. From the obtained results, the input impedance of zigzag IFA is  $66.70006 \Omega$  at 5.5 GHz without impedance matching network and the impedance away from  $50 \Omega$ . So impedance matching network is necessary. Using matching network between the source and the antenna, the input impedance of zigzag IFA is found to be  $50.20454 \Omega$  at 5.5 GHz and the impedance variation is very low within the operating band. So with impedance matching network the input impedance of the proposed antenna is near about  $50 \Omega$ .

Fig. 12 represents the antenna phase shift causes due to the impedance mismatch as a function of frequency. Also, from the simulation study, the antenna offers a phase shift of  $-50.68816^\circ$  without matching network. Besides with matching network the phase shift is  $-0.29023^\circ$ . With matching network the phase shift of zigzag IFA closer to  $0^\circ$  all over the antenna bandwidth. Fig. 13 represents the radiation patterns of the antenna at 5.5 GHz resonant frequency for total gain in E and H-plane. The antenna's normalized total radiation in E and H-plane is almost omnidirectional at the 5.5 GHz Wi-Fi operating frequency.

Peak gain comparison with the proposed antenna and reference antennas for Wi-Fi application are listed in Table III. From the comparison table, proposed zigzag IFA has much higher gain than the antennas have been proposed earlier for 5.5 GHz Wi-Fi operation. In overall considerations, zigzag inverted-F antenna is much better than all other antennas.



(a)

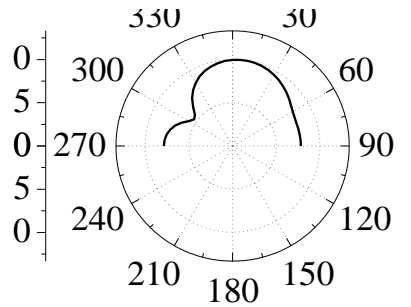

(b)

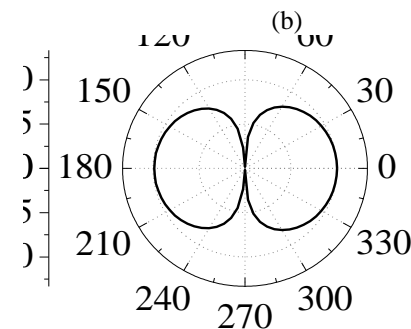

(c)

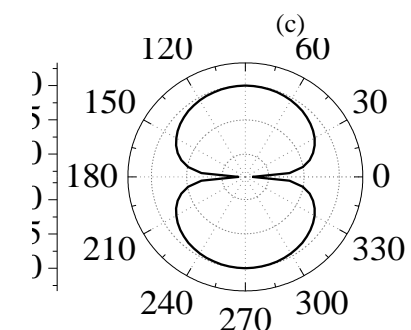

(d)

**Fig. 13. Normalized (a) Total gain pattern in E-plane, (b) Total gain pattern in H-plane, (c) Vertical gain pattern in E-plane (d) Horizontal gain pattern in E-plane of zigzag IFA at 5.5 GHz.**



TABLE III. Gain comparison between the proposed and reference antennas

Antenna	Peak Gain (dBi) at 5.5 GHz Wi-Fi
Zigzag inverted-F (Proposed)	6.91
T-shaped monopole [2]	1.0
Composite monopole [3]	4.6-5.3
Metal-plate antenna [5]	4.6-5.2
Flat-plate antenna with a shorted parasitic element [6]	4.2-5.7
Internal PIFAs [7]	4.1-5.5
Uni-planar dual-band monopole antenna [8]	5.0-5.9
Printed monopole antenna [9]	5.05-5.95

#### IV. CONCLUSION

Optimized impedance matched zigzag IFA for Wi-Fi operation in portable devices is proposed using numerical simulations. The antenna occupies extremely small area with bandwidth of 609 MHz (5250~5859 MHz). Moreover the gain of the antenna is high and the gain variation is very low within the operating band. From the analysis, the gain, radiation pattern, return loss, input impedance, VSWR and phase shift of the antenna is suitable for the specified applications than the antennas proposed earlier. Due to the compact area occupied, the proposed antenna is promising to be embedded within portable devices.

#### V. REFERENCES

1. L. Pazin, N. Telzhensky and Y. Leviatan, "Multiband Flat-Plate inverted-F antenna for Wi-Fi/WiMAX operation", *IEEE antennas and wireless propagation letters*, Vol. 7, pp. 197-200, 2008.
2. J. -W. Wu, Y. -D. Wang, H. -M. Hsiao and J. -H. Lu, "T-Shaped Monopole Antenna with Shorted L-Shaped Strip-Sleeves for WLAN 2.4/5.8-GHz Operation", *Microwave and Optical Technology Letters*, Vol. 46, No. 1, pp. 65-69, 2005.
3. K. -L. Wong, and L. -C. Chou, "Internal Composite Monopole Antenna for WLAN/WiMAX Operation In A Laptop Computer", *Microwave and Optical Technology Letters*, Vol. 48, No. 5, pp. 868-871, 2006.
4. K. L. Chung, T. H. Mak, and W. Y. Tam, "A Modified Two-Strip Monopole Antenna for Wi-Fi and WiMAX Applications", *Microwave and Optical Technology Letters*, Vol. 51, No. 12, pp. 2884-2886, 2009.
5. K. -L. Wong and L. -C. Chou, "Internal Wideband Metal-Plate Antenna for Laptop Application", *Microwave and Optical Technology Letters*, Vol. 46, No. 4, pp. 384-387, 2005.
6. K. -L. Wong, L. -C. Chou and C. -M. Su, "Dual-Band Flat-Plate Antenna with a Shorted Parasitic Element for Laptop Applications", *IEEE Transactions on Antennas and Propagation*, Vol. 53, No. 1, pp. 539-544, 2005.
7. W. C. Su and K. -L. Wong, "Internal PIFAS for UMTS/WLAN/WiMAX Multi-Network Operation for a USB Dongle" *Microwave and Optical Technology Letters*, Vol. 48, No. 11, pp. 2249-2253, 2006.
8. L. -C. Chou and K. -L. Wong, "Uni-Planer Dual -Band Monopole Antenna for 2.4/5 GHz WLAN Operation in a Laptop Computer" *IEEE Transactions on Antennas and Propagation*, Vol. 55, No. 12, pp. 3739-3741, 2007.
9. C. -Y. Pan, T. -S. Horng, W. -S. Chen, and C. -H. Huang, "Dual Wideband Printed Monopole Antenna for WLAN/ WiMAX Applications" *IEEE antennas and wireless propagation letters*, Vol. 6, pp. 149-151, 2007.
10. G. J. Burke, and A. J. Poggio, "Numerical Electromagnetic Code-2", Ver. 5.7.5, Arie Voors, 1981.

#### AUTHORS PROFILE



**Md. Selim Hossain** was born in Kushtia, Bangladesh. He received the Bachelor of Science in Electrical & Electronic Engineering (EEE) Degree from Khulna University of Engineering & Technology (KUET), Khulna-9203, Bangladesh, in 2008. He completed the SPACE (Saga University Programs for Academic Exchange) program from Saga University, Japan in 2007. He is currently working as a Lecturer in the same department of EEE, KUET. He has authored or coauthored over 10 referred journal and conference papers. His research interests include analysis and design of microstrip filter for microwave communication, measurement system, microstrip antennas, antennas for biomedical and RFID applications, antenna miniaturization. Mr. Hossain is a member of Consultancy Research and Testing Services (CRTS), KUET and an Associate Member of Institute of Engineers Bangladesh (IEB).



**Debabrata Kumar Karmokar** was born in Satkhira, Bangladesh, in 1985. He received the B. Sc. in Electrical & Electronic Engineering Degree from Khulna University of Engineering & Technology (KUET), Khulna, Bangladesh, in 2007. He is currently working as an Assistant Professor with the department of Electrical & Electronic Engineering, KUET. He has authored and co-authored more than 25 publications in refereed journals and conference proceedings. His main interests include antennas and wave propagation, analysis and design of microstrip antennas, photonic band gap based antennas, multi-band and broadband printed antennas, medical applications of microwaves and wireless technology, small antennas for mobile communications, RFID, power system & power quality studies and renewable energy. Mr. Karmokar is a member of Consultancy Research and Testing Services (CRTS), department of Electrical and Electronic Engineering, KUET and a member of the Institution of Engineers Bangladesh (IEB).



**Khaled Mahub Morshed** received Bachelor of Science in electronics & communication engineering (ECE) with honors from Khulna University of Engineering & Technology, Khulna – 9203, Bangladesh, in 2007. He is currently working as a Assistant Professor in the same department of this university. He authored and co-authored more than 25 publications in refereed journals and conference proceedings in national and international level. His current research interests include analysis and design of microstrip/patch antennas, antennas for biomedical and RFID applications, antenna miniaturization, high gain microstrip antennas for satellite communications, eletromagnetics. Mr. Morshed is a Member of Institute of Engineers Bangladesh (IEB), Life Member of Bangladesh Electronic Society (BES).