

Design of Adaptive Fuzzy PID Controller for Speed control of BLDC Motor

R. Kandiban, R. Arulmozhiyal

Abstract—Brushless DC motors (BLDCM) are widely used for many industrial applications because of their high efficiency, high torque and low volume. This paper proposed an improved Adaptive Fuzzy PID controller to control speed of BLDCM. This paper provides an overview of performance conventional PID controller, Fuzzy PID controller and Adaptive Fuzzy PID controller. It is difficult to tune the parameters and get satisfied control characteristics by using normal conventional PID controller. As the Adaptive Fuzzy has the ability to satisfied control characteristics and it is easy for computing. The experimental results verify that a Adaptive Fuzzy PID controller has better control performance than the both Fuzzy PID controller and conventional PID controller. The modeling, control and simulation of the BLDC motor have been done using the software package MATLAB/SIMULINK.

Index Terms— Brushless DC (BLDC) motors, proportional integral derivative (PID) controller, Fuzzy PID controller, Adaptive Fuzzy PID controller.

I. INTRODUCTION

There are mainly two types of dc motors used in industry. The first one is the conventional dc motor where the flux is produced by the current through the field coil of the stationary pole structure. The second type is the brushless dc motor where the permanent magnet provides the necessary air gap flux instead of the wire-wound field poles. BLDC motor is conventionally defined as a permanent magnet synchronous motor with a trapezoidal Back EMF waveform shape. As the name implies, BLDC motors do not use brushes for commutation; instead, they are electronically commutated. Recently, high performance BLDC motor drives are widely used for variable speed drive systems of the industrial applications and electric vehicles.

In practice, the design of the BLDCM drive involves a complex process such as modeling, control scheme selection, simulation and parameters tuning etc. Recently, various modern control solutions are proposed for the speed control design of BLDC motor [1-3]. However, Conventional PID controller algorithm is simple, stable, easy adjustment and high reliability, Conventional speed control system used in conventional PID control [4][5]. But, in fact, most industrial processes with different degrees of nonlinear, parameter

variability and uncertainty of mathematical model of the system. Tuning PID control parameters is very difficult, poor robustness, therefore, it's difficult to achieve the optimal state under field conditions in the actual production.

In this paper an Adaptive-fuzzy PID control is introduced in speed regulation system of BLDC motor. Parameter can be adjusted real time under adaptive fuzzy PID control. In order to improve the performance of the Adaptive-fuzzy PID controller system an increase in the number of inputs and membership functions was necessary, at the same time the individual set of rules are formed for each Kp, Ki and Kd. By using individual set of rules, the controller can be adapt to any change of parameter. But in Fuzzy PID controller only common set of rule are formed for Kp, Ki and Kd.

The aim of this paper is that it shows the dynamics response of speed with design the Adaptive-fuzzy PID controller to control a speed of motor for keeping the motor speed to be constant when the load varies. The simulation result show that the performance of the Adaptive Fuzzy PID controller has been has better control performance than the both Fuzzy PID controller and conventional PID controller.

II. SPEED CONTROL SYSTEM OF BLDC MOTOR

The complete block diagram of speed control of three phase BLDC Motor is below Fig. 1. Two control loops are used to control BLDC motor. The inner loop synchronizes the inverter gates signals with the electromotive forces. The outer loop controls the motor's speed by varying the DC bus voltage.

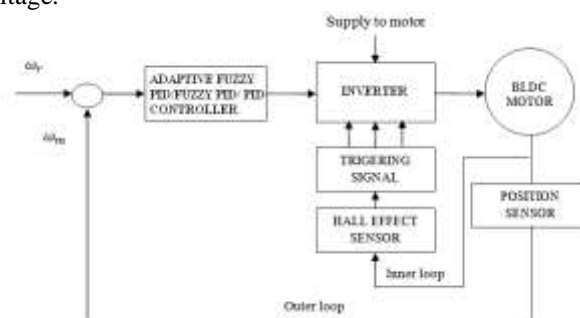

Figure 1. Block Diagram of speed control of BLDC Motor

Driving circuitry consists of three phase power convertors, which utilize six power transistors to energize two BLDC motor phases concurrently. The rotor position, which determines the switching sequence of the MOSFET

Revised Manuscript Received on March 2012.

R.Kandiban, PG Student, Department of Electrical and Electronics Engineering, Sona College of Technology, Salem, India, (e-mail: kandiban.r@gmail.com).

Dr. R. Arulmozhiyal, Associate Professor, Department of Electrical and Electronics Engineering, Sona College of Technology, Salem, India, (e-mail: arulmozhiyal@gmail.com).

transistors, is detected by means of 3 Hall sensors mounted on the stator. By using Hall sensor information and the sign of reference current (produced by Reference current generator), Decoder block generates signal vector of back EMF. The basic idea of running motor in opposite direction is by giving opposite current. Based on that, we have Table I for calculating back EMF for Clockwise of motion and the gate logic to transform electromagnetic forces to the 6 signal on the gates is given Table II.

TABLE I. CLOCKWISE ROTATION

Hall sensor A	Hall sensor B	Hall sensor c	EMF A	EMF B	EMF C
0	0	0	0	0	0
0	0	1	0	-1	1
0	1	0	-1	1	0
0	1	1	-1	0	1
1	0	0	1	0	-1
1	0	1	1	-1	0
1	1	0	0	1	-1
1	1	1	0	0	0

TABLE II. GATE LOGIC

EMF A	EMF B	EMF C	Q1	Q2	Q3	Q4	Q5	Q6
0	0	0	0	0	0	0	0	0
0	-1	1	0	0	0	1	1	0
-1	1	0	0	1	1	0	0	0
-1	0	1	0	1	0	0	1	0
1	0	-1	1	0	0	0	0	1
1	-1	0	1	0	0	1	0	0
0	1	-1	0	0	1	0	0	1
0	0	0	0	0	0	0	0	0

III. CONTROLLER CIRCUIT

A. PID Controller

Consider the characteristics parameters – proportional (P), integral (I), and derivative (D) controls, as applied to the diagram below in Fig.2, the system,

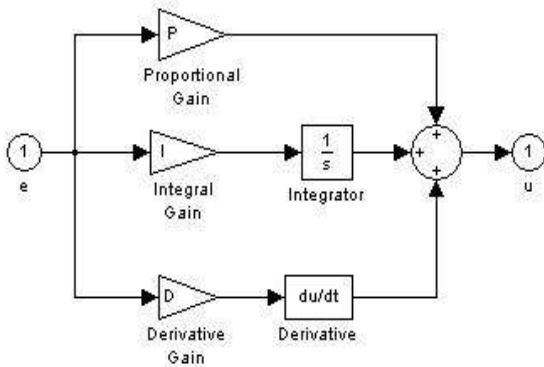

Figure 2. Simulation model of PID Controller

A PID controller is simple three-term controller. The letter P, I and D stand for P- Proportional, I- Integral, D-

Derivative. The transfer function of the most basic form of PID controller, is

$$C(S) = K_p + \frac{K_I}{S} + K_D S \tag{1}$$

$$C(S) = \frac{K_D S^2 + K_P S + K_I}{S} \tag{2}$$

Where K_p = Proportional gain, K_i = Integral gain and K_D = Derivative gain.

The control u from the controller to the plant is equal to the Proportional gain (K_p) times the magnitude of the error plus the Integral gain (K_i) times the integral of the error plus the Derivative gain (K_d) times the derivative of the error.

$$u = K_p e + K_i \int edt + K_d \frac{de}{dt} \tag{3}$$

Due to its simplicity and excellent if not optimal performance in many applications, PID controllers are used in more than 95% of closed-loop industrial processes

We are most interested in four major characteristics of the closed-loop step response. They are

- a. Rise Time: the time it takes for the plant output Y to rise beyond 90% of the desired level for the first time.
- b. Overshoot: how much the peak level is higher than the steady state, normalized against the steady state.
- c. Settling Time: the time it takes for the system to converge to its steady state.
- d. Steady-state Error: the difference between the steady-state output and the desired output.

The Values of K_p , K_i and K_d values of PID Controller is shown in below table III are obtained by using the ZN method.

TABLE III. PID VALUES

controller	K_p	K_i	K_d
PID	0.8	48	0.01

B. Fuzzy PID Controller

Fuzzy PID controller used in this paper is based on two inputs and one output. The overall structure of used controller is shown in Fig. 3. In Fuzzy PID controller only one output which are connected to K_p , K_i and K_d .

Real interval of variables is obtained by using scaling factors which are S_e , S_d and S_u . The fuzzy control rule is in the form of: IF $e=E_i$ and $ce=dE_j$ THAN $U_{PD}=U_{PD}(i,j)$. These rules are written in a rule base look-up table which is shown in Fig. 3. The rule base structure is Mamdani type.

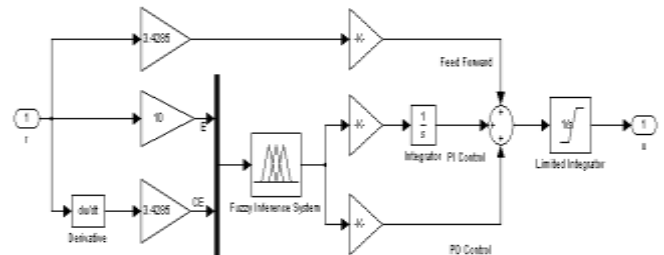

Figure 3. Simulation of Fuzzy PID Controller



FLC has two inputs and one output. These are error (e), error change (de) and control signal, respectively. A linguistic variable which implies inputs and output have been classified as: NB, NM, NS, Z, PS, PM, PB. Inputs and output are all normalized in the interval of [-3,3] as shown in Fig. 4.

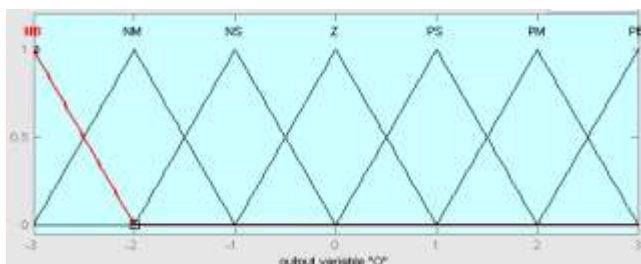

Figure 4. Membership functions of output

The linguistic labels used to describe the Fuzzy sets were ‘Negative Big’ (NB), ‘Negative Medium’ (NM), ‘Negative Small’ (NS), ‘Zero’ (Z), ‘Positive Small’ (PS), ‘Positive Medium’ (PM), ‘Positive Big’ (PB). It is possible to assign the set of decision rules as shown in Table IV. The fuzzy rules are extracted from fundamental knowledge and human experience about the process. These rules contain the input/the output relationships that define the control strategy. Each control input has seven fuzzy sets so that there are at most 49 fuzzy rules.

TABLE IV. TABLE OF FUZZY RULE

CE \ E	NB	NM	NS	Z	PS	PM	PB
NB	NB	NB	NB	NB	NM	NS	Z
NM	NB	NB	NB	NM	NS	Z	PS
NS	NB	NB	NM	NS	Z	PS	PM
Z	NB	NM	NS	Z	PS	PM	PB
PS	NM	NS	Z	PS	PM	PB	PB
PM	NS	Z	PS	PM	PB	PB	PB
PB	Z	PS	PM	PB	PB	PB	PB

C. Adaptive Fuzzy PID controller

Adaptive Fuzzy PID controller used in this paper is based on two input and three output. The overall structure of used controller is shown in Fig. 5. In Fuzzy PID controller have three outputs which are Kp, Ki and Kd.

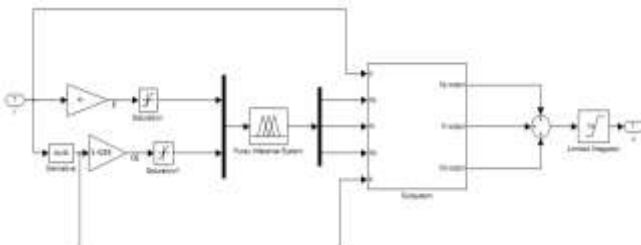

Figure 5. Adaptive Fuzzy PID Controller

Error speed (E) and Change in error speed (CE) as fuzzy control input and fuzzy outputs are ΔKp , ΔKi , Δkd .

$$\Delta Kp = Kp.\Delta Kp^1 \quad (4)$$

$$\Delta Ki = Ki.\Delta Kp^1 \quad (5)$$

$$\Delta Kd = Kd.\Delta Kp^1 \quad (6)$$

A linguistic variable which implies inputs and output have been classified as: NB, NM, NS, Z, PS, PM, PB. Inputs normalized in the interval of [-3,3] and output ΔKp interval [-1,1], ΔKi interval [-1,1] and ΔKd interval [-0.005,0.005]. The output membership of ΔKp fuzzy set is shown fig.6.

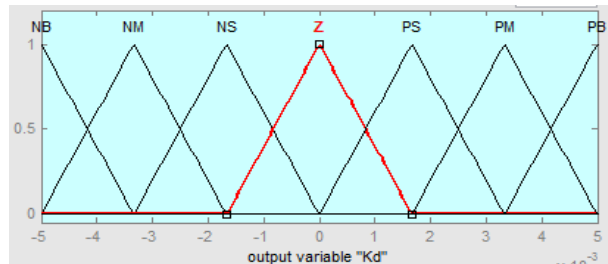

Figure 6. Membership function of Kp output

TABLE V. TABLE OF FUZZY RULE FOR ΔKp

CE \ E	NB	NM	NS	Z	PS	PM	PB
NB	PB	PB	PM	PM	PS	PS	Z
NM	PB	PB	PM	PS	PS	Z	NS
NS	PB	PM	PM	PS	Z	NS	NS
Z	PM	PM	PS	Z	NS	NM	NM
PS	PS	PS	Z	NS	NS	NM	NM
PM	PS	Z	NS	NM	NM	NM	NB
PB	Z	NS	NS	NM	NM	NB	NB

This paper uses a mamdani fuzzy inference reasoning algorithm and ambiguity resolution uses center of gravity method. Then, the output of ΔKp , ΔKi , Δkd can be obtained by ambiguity resolution.

IV. SIMULATION RESULT AND DISCUSSION

Fig. 7 as shown performance of the Adaptive Fuzzy PID controller, Fuzzy PID controller and Conventional PID Controller of BLDC Motor on Reference speed of 3000rpm with no load condition of (a) speed and (b) Torque. The results show that conventional PID controller, fuzzy PID controller and fuzzy PID controller reach settling time are 0.35 sec, 0.10 and 0.10 sec respectively.

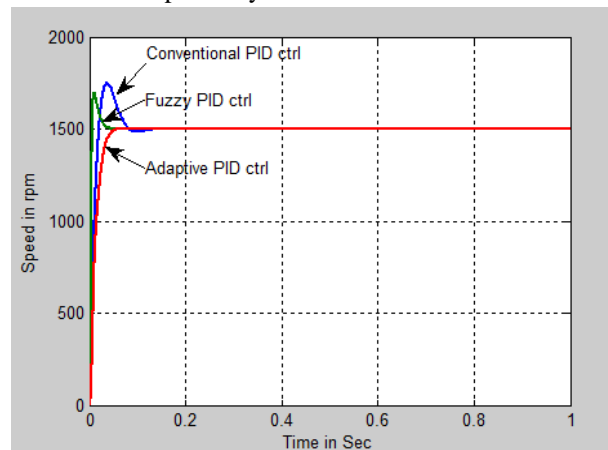

(a)

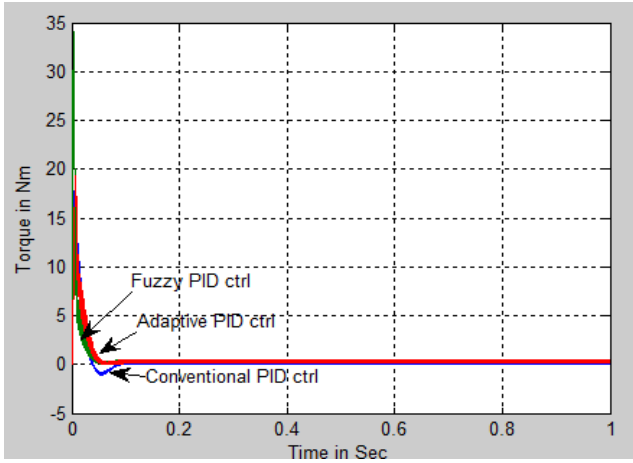

(b)

Figure 7. Reference speed of 3000 rpm with no load (a) Speed and (b) Torque

Fig. 8 as shown performance of the Adaptive Fuzzy PID controller, Fuzzy PID controller and Conventional PID Controller of BLDC Motor on stepdown speed of 3000rpm with load condition of (a)speed and (b)Torque. . The results show that conventional PID controller, fuzzy PID controller and fuzzy PID controller reach settling time are 0.35 sec, 0.10 and 0.10 sec respectively.

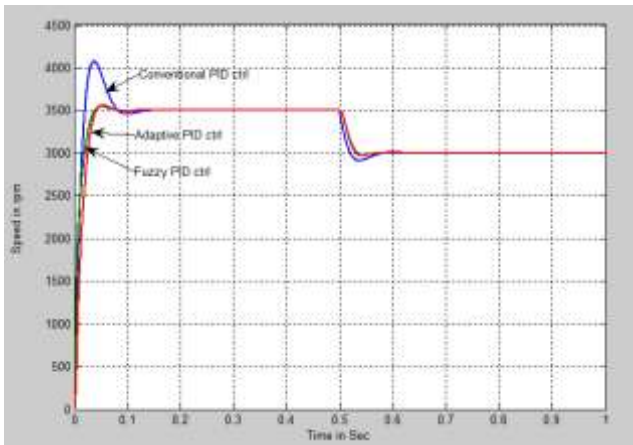

(a)

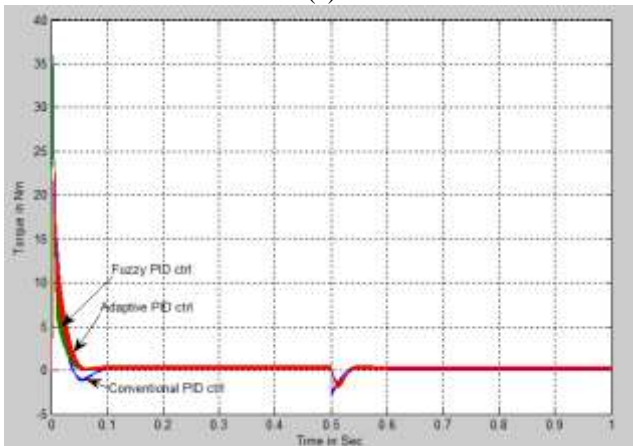

(b)

Figure 8. Stepdown speed of 3500 - 3000 rpm with no load (a)Speed and (b) Torque

Fig. 9 as shown performance of the fuzzy PID controller and Conventional PID Controller of BLDC Motor on speed of 3000rpm with load impact condition of (a)speed and

(b)Torque. During running conduction of BLDC motor, suddenly the load of 5 N.m is applied at time of 0.5 sec and released at 0.7 sec. The results show that conventional PID controller reach settling time is 0.35 sec, but in fuzzy PID controller reach the settling time of 0.15 sec.

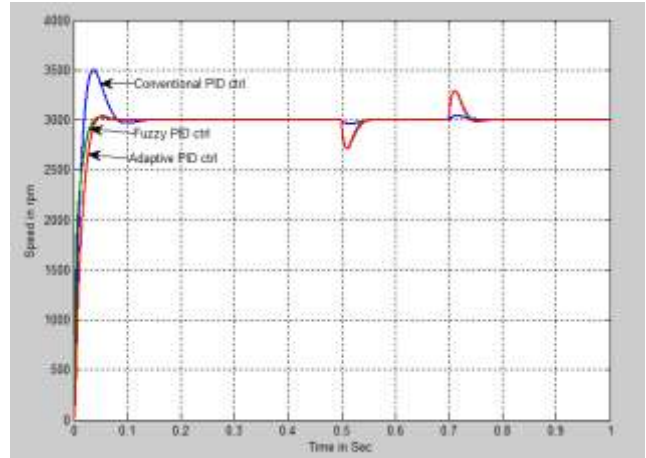

(a)

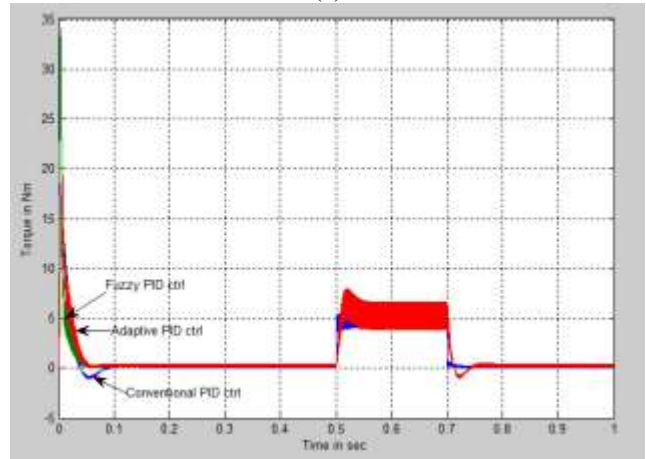

(b)

Figure 9. Reference speed of 3000 rpm with load impact (a) Speed and (b) Torque

To evaluate the performance of the system, a series of measurements has been accomplished. The performance results of Conventional PID controller, Fuzzy PID controller and Adaptive Fuzzy PID controller of three phases BLDC Motor is shown in below Table VI, VII and VIII respectively. We consider the following characteristics Rise Time (t_r), overshoot (M_p) and Settling Time (t_s).

TABLE VI. PERFORMANCE RESULT F CONVENTIONAL PID CONTROLLER

Speed	PID Controller		
	t_r	$\%M_p$	t_s
1500 no load	0.020	16.5	0.3
	2	3	5
1500load	0.020	16.6	0.3
	6	0	5
3000no load	0.020	15.5	0.4
	9	3	0
3000withload	0.021	15.7	0.4
	0	1	0

1000 – 1500 no-load	0.020 1	16.4 0	0.3 5
1000 – 1500 withload	0.020 5	16.6 0	0.3 5
3000 - 3500 no-load	0.020 9	15.4 0	0.3 5
3000 - 3500 withload	0.020 9	15.7 0	0.3 5
1500 - 1000 no-load	0.020 2	16.5 3	0.3 5
1500 - 1000 withload	0.020 6	16.6 0	0.3 5
3500 - 3000 no-load	0.020 9	15.5 3	0.3 5
3500 - 3000 withload	0.021 0	15.7 1	0.3 5
1500 load impact	0.020 2	16.5 3	0.3 5
3000 load impact	0.020 6	16.6 0	0.3 5

TABLE VII. PERFORMANCE RESULT OF FUZZY PID CONTROLLER

Speed	Fuzzy PID Controller		
	t_r	$\%M_p$	t_s
1500 no-load	0.0061	13.13	0.10
1500load	0.0390	1.37	0.25
3000no-load	0.0077	3.60	0.15
3000withload	0.0522	0.42	0.25
1000 – 1500 no-load	0.0042	55.10	0.15
1000 – 1500 withload	0.0391	0.86	0.20
3000 - 3500 no-load	0.0051	40.30	0.15
3000 - 3500 withload	0.0556	0.23	0.20
1500 - 1000 no-load	0.0061	13.13	0.15
1500 - 1000 withload	0.039	1.37	0.25
3500 - 3000 no-load	0.0077	3.6	0.15
3500 - 3000 withload	0.0522	0.42	0.25
1500 load impact	0.0061	13.13	0.15
3000 load impact	0.0390	1.6	0.25

TABLE VIII. PERFORMANCE RESULT OF FUZZY PID CONTROLLER

Speed	Adaptive Fuzzy PID Controller		
	t_r	$\%M_p$	t_s
1500 no-load	---	---	0.10
1500load	---	---	0.10
3000no-load	0.0432	1.23	0.17
3000withload	0.0553	0.33	0.15

1000 – 1500 no-load	---	---	0.57
1000 – 1500 withload	---	---	0.59
3000 - 3500 no-load	0.5325	0.85	0.62
3000 - 3500 withload	0.5382	0.371	0.65
1500 - 1000 no-load	---	--	0.58
1500 - 1000 withload	--	--	0.59
3500 - 3000 no-load	0.5731	0.033	0.69
3500 - 3000 withload	---	---	0.65
1500 load impact	---	---	0.10
3000 load impact	0.0432	1.23	0.16

From performance comparison a Fuzzy PID controller has better control performance than the conventional PID controller

V. CONCLUSION

This paper presents simulation results of conventional PID controller, Fuzzy PID controller and Adaptive Fuzzy PID controller of three phase BLDC Motor. In conventional PID control it is not necessary to change the control parameters as the reference speed changes. With results obtained from simulation, it is clear that for the same operation condition the BLDC speed control using Adaptive Fuzzy PID controller technique had better performance than the conventional PID controller and Fuzzy PID controller, mainly when the motor was working at lower and higher speeds. In addition, the motor speed to be constant when the load varies.

REFERENCES

1. J.E Miller, "Brushless permanent-magnet motor drives," Power Engineering Journal, vol.2, no. 1, Jan. 1988.
2. Q.D.Guo,X.MZhao. BLDC motor principle and technology application [M]. Beijing: China electricity press,2008.
3. Uzair Ansari, Saqib Alam, Syed Minhaj un Nabi Jafri, "Modeling and Control of Three Phase BLDC Motor using PID with Genetic Algorithm", 2011 UKSim 13th International Conference on Modelling and Simulation,pp.189-194.
4. K. Ang, G. Chong, and Y. Li, "PID control system analysis, design and technology," IEEE Trans.Control System Technology, vol. 13, pp. 559-576, July 2005.
5. Atef Saleh Othman Al-Mashakbeh, "Proportional Integral and Derivative Control of Brushless DC Motor", European Journal of Scientific Research 26-28 July 2009, vol. 35, pg 198-203.
6. Chuen Chien Lee, "Fuzzy Logic in Control Systems:Fuzzy Logic controller-Part 1" 1990 IEEE.
7. Chuen Chien Lee, "Fuzzy Logic in Control Systems : Fuzzy Logic controller Part 2" 1990 IEEE.
8. Zdenko Kovacic and Stjepan Bogdan, "Fuzzy Controller design Theory and Applications", © 2006 by Taylor & Francis Group. international, 2002.
9. R.Arulmozhiyal and K.Baskaran, "Implementation of Fuzzy PI Controller for Speed Control of Induction Motor Using FPGA", Journal of Power Electronics, Vol.10, No.1, Jan 2010, pp.65-71



AUTHOR PROFILE



R.Kandiban was born in salem, tamilnadu, India in 1988. He received the B.E. degree in Electronic and Communication Engineering, Anna university chennai, Tamilnadu, India. Now he is PG student in Departement of Electrical and Electronic Engineering, sona college of technology, salem, tamilnadu, India.



Dr.R.Arulmozhiyal was born in chennai, Tamilnadu, India in 1973. She received the B.E. and M.E. degrees in electrical engineering from University of the Madras, Anna, India, in 1999 and 2006, respectively. and the Ph.D. degree in Electrical engineering from Anna University of technology, Coimabtoe, India, in 2011. Since 1999, She has been with Department of Electrical and Electronics Engineering, Faculty of Engineering, Sona College of Technology, Tamilnadu, India where she is currently a Associate Professor. Her research interests are in the areas of AC Motor Control, AI Techniques to Solid State Drives. Mrs. Arulmozhiyal is a Member in IEEE society, life member in ISTE and member in IE(I).