

Optical Fiber Communication System Performance using MZI Switching

Sachin Kumar, Indu Bala Pauria, Anoop Singhal

Abstract: first a simple all-optical logic device, called Mach Zehnder Interferometer is composed by using a Semiconductor Optical Amplifier (SOA) and an optical coupler. This device is used for generating the logical functions (AND, XOR) and a multiplexer and an Encoder is obtained using this device in Optical Tree Architecture. The simulation of Encoder and Multiplexer is done at a rate of 10 Gbit/s and both are simulated for different input logical combinations. Simulations indicate that the device is suitable to operate at much higher bit rate and also for different logical entities.

Many lower-speed data streams can be multiplexed into one high-speed stream by means of Optical time division multiplexing (OTDM), such that each input channel transmits its data in an assigned time slot. The assignment is performed by a fast multiplexer switch (mux). The routing of different data streams at the end of the TDM link is performed by a demultiplexer switch (demux) and this demultiplexer is employed using MZI switch as it consists a semiconductor optical amplifier (SOA) and a optical coupler. In this chapter four channel OTDM is simulated at 40 Gbit/s and further it is investigated the impact of the signal power, pulse width and control signal power on BER.

Index Terms: All optical switch, Mach-Zehnder interferometer (MZI), Semiconductor optical amplifiers (SOA), Switching schemes, Spectrum analysis.

I. INTRODUCTION

In the information age, technologies seeing a relentless demand for networks of higher capacities at lower costs. Optical communication technology has developed rapidly to achieve larger transmission capacity and longer transmission distance. For that such data rates can be achieved if the data remain in the optical domain eliminating the need to convert the optical signals. Therefore, to successfully be able to achieve higher data rates, advanced optical networks will require all optical ultra fast signal processing such as wavelength conversion, optical logic and arithmetic processing, add-drop function, etc. Various architectures, algorithms, logical and arithmetic operations have been proposed in the field of optical/optoelectronic computing and parallel processing in the last three decades. Nonlinear optical loop mirror (NOLM) provides a major support to optical switching based all optical logic and algebraic processing where the switching mechanism is based on fiber Kerr nonlinearities.

Manuscript received on July, 2012

Sachin Kumar, M.Tech Scholar, Department of ECE, Suresh Gyan Vihar University, Jaipur(Rajasthan), India

Indu Bala Pauria, M.Tech Scholar, Department of ECE, Suresh Gyan Vihar University, Jaipur(Rajasthan), India

Prof. Anoop Singhal, Asst. Professor, Department of ECE, Suresh Gyan Vihar University, Jaipur(Rajasthan), India

More efficient and compact solutions can be realized by all optical switching in semiconductor optical amplifiers (SOAs) where the non linear coefficient is much higher.

Various SOA based switching configurations have been demonstrated earlier such as Tetrahertz optical asymmetric demultiplexers (TOADs), ultra-fast nonlinear interferometers (UNIs) and Mach-Zehnder interferometers (MZIs). Among different topologies, monolithically integrated MZI switches represent the most promising solution due to their compact size, thermal stability and low power. In optical computing, optical interconnecting systems are the primitives that constitute various optical algorithms and architectures. Optical tree architecture (OTA) also takes an important role in this regard. So in this era of rapidly changing technology we represent a new alternative scheme which exploits advantages of both SOA-MZI and OTA, for implementation of all optical parallel logic and arithmetic operations of binary data.

1.1 Mach Zehnder Interferometer

The Mach-Zehnder Interferometer is a device used to determine the phase shift caused by a small sample which is placed in the path of one of two collimated beams from a coherent two light source. A Mach-Zehnder Interferometer is created from two couplers connected by arms of unequal optical length. The Mach-Zehnder Interferometer has two input ports and two output ports. The light is split in the two arms of the input coupler of the interferometer, and they are later recombined in the output coupler of the interferometer. The optical length of

the two arms is unequal, making the phase corresponding to delay in Fig.1.1 to be a function of wavelength. The relative phase of the light in the two input ports of the output coupler is therefore a function of wavelength. As the phase of the delay (d) is increased, the MZI cycles between the cross state, where most of the light appears in the waveguide on the same side as the input, and the bar state, where most the light moves to the waveguide on the other side.

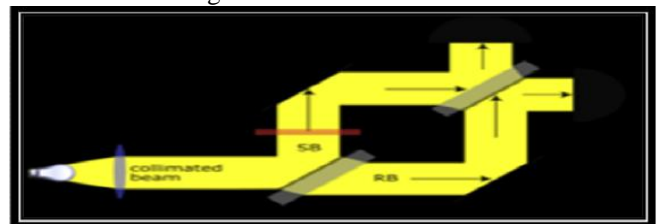

Fig.1.1 Mach-Zehnder Interferometer

1.2 Semiconductor Optical Amplifier

Semiconductor optical amplifiers are amplifiers which use a semiconductor to provide the gain medium. Recent designs include anti-reflective coatings and tilted waveguide and window regions which can reduce end face reflection to less than 0.001%. Since this creates a loss of power from the cavity which is greater than the gain it prevents the amplifier from acting as a laser. Such amplifiers are often used in telecommunication systems in the form of fiber-pigtailed components, operating at signal wavelengths between 0.85 μm and 1.6 μm and generating gains of up to 30 dB. The semiconductor optical amplifier is of small size and electrically pumped. It can be potentially less expensive than the EDFA and can be integrated with semiconductor lasers, modulators, etc. However, the performance is still not 5 comparable with the EDFA. The SOA has higher noise, lower gain, and moderate polarization dependence and high nonlinearity with fast transient time. This originates from the short nanosecond or less upper state lifetime, so that the gain reacts rapidly to changes of pump or signal power and the changes of gain also because phase changes which can distort the signals. This nonlinearity presents the most severe problem for optical communication applications. However it provides the possibility for gain in different wavelength regions from the EDFA.

1.3 Categories of switch

1.3.1 MZI Switch

The Mach-Zehnder interferometer (MZI) based switch consists of a 3 dB splitter and a 3 dB combiner, connected by two interferometer arms. By changing the effective refractive index of one of the arms, the phase difference at the beginning of the combiner can be changed, such that the light switches from one output port to the other. This switch has the advantage that the phase shifting part and the mode coupling part are separated, such that both can be optimized separately.

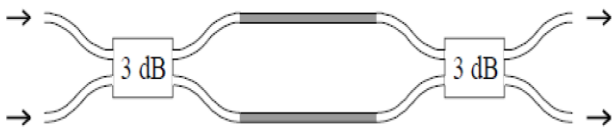

Fig.1.2 MZI based switch

A small effective refractive index change in the interferometer is sufficient for the switching. The disadvantages are its length and the accurate refractive index change that is required for switching. When multimode interference couplers are employed as 3 dB splitter and combiner, a fabrication tolerant and polarization insensitive wave guiding structure is obtained. A low power data signal is focused into the central input waveguide such that it splits into two equal parts at the Y-junction power splitter. These two beams then propagate through the two arms of the Mach-Zehnder and recombine constructively at the 6 output Y-junction power combiner and propagate along the output waveguide. A high power control signal is also focused into one of the outer wave guides to produce a nonlinear refractive index change in the waveguide via the nonlinear optical Kerr effect. This produces a phase difference between the two data signals at the output Y junction causing them to interfere destructively when the phase difference between them is TC

radians. Under this condition, the data signal is coupled into radiation modes and the output falls to zero. Subsequently the device may be used as a modulator.

1.3.2 DC Switch

In a directional coupler switch two adjacent waveguides are designed such, that the light can be transferred from one waveguide to the other by coupling. The switching is obtained by properly adjusting the effective refractive index of one of the waveguides. For switching only a small refractive index change is needed.



Fig 1.3 Directional Coupler Switch

For a good transfer of the light, an accurate coupling length is required. Since this length is usually polarization and wavelength dependent and strongly influenced by fabrication deviations (etch depth, waveguide spacing), a good switch performance is hard to obtain.

1.3.3 SOA based MZI Switch

A semiconductor optical amplifier can both be used for amplification and attenuation of an optical signal, by turning the gain on and off. This property can be employed for a simple but effective way of switching by splitting an optical signal with a 3 dB splitter, after which this signal is attenuated in one arm and amplified in the other arm. Since the splitter losses and additional losses (e.g. fiber-chip coupling loss) can be compensated by the SOA, this type of switch can have low loss or even gain and, in addition, excellent on-off ratios leading to low crosstalk levels.

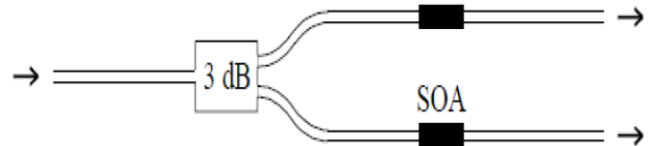

Fig 1.4 SOA based MZI Switch

The most important disadvantage of a SOA switch is its high additional noise level in the “on” state caused by spontaneous emission generated in the SOA.

1.4 OPTSIM

Optsim is an advanced optical communication system simulation package designed for professional engineering and cutting-edge research of WDM, DWDM, TDM, CATV, optical LAN, parallel optical bus, and other emerging optical systems in telecom, datacom, and other applications. It can be used to design optical communication systems and simulate them to determine their performance considering various component parameters.

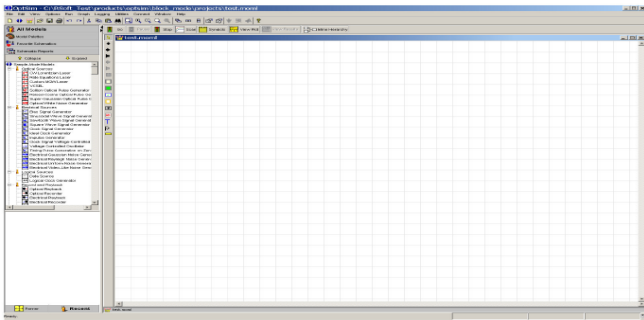

Fig 1.5 Optisim graphical editor

Optisim is designed to combine the greatest accuracy and modeling power with ease of use on both Windows and UNIX platforms. Optisim represents an optical communication system as an interconnected set of blocks, with each block representing a component or subsystem in the communication system. As physical signals are passed between components in a real world communication system, “signal” data is passed between component models in the Optisim simulation.

II. LITERATURE SURVEY

2.1 All-Optical Logic by MZI switch

Koji Igarashi et al. described optical signal processing based on optical phase modulation and subsequent optical filtering, which is applicable to 160-Gb/s optical time-division multiplexed (OTDM) subsystems. Ultrafast phase modulation of an optical signal is done by self-phase modulation (SPM) and cross-phase modulation (XPM) when an optical pulse passes through a nonlinear optical fiber. Such phase modulation induces the spectral shift of the optical signal. Jian Wang ET. Al. presented ultrafast logic AND gate for carrier-suppressed return-to-zero (CSRZ) signals by exploiting two kinds of cascaded second-order nonlinearities in a periodically poled lithium neonate (PPLN) waveguide. The analytical solutions are derived under the no depletion approximation clearly describing the principle of operation. First, based on cascaded second-harmonic generation and difference-frequency generation (CSHG/DFG) in a PPLN, an all-optical 40 Gbit/s CSRZ logic AND gate is successfully implemented in the experiment and verified by numerical simulations. It is found that the converted idler, taking the AND result, keeps the CSRZ modulation format unchanged. Second, by using cascaded sum- and difference-frequency generation (CSFG/DFG) in a PPLN. By modifying the design of an existing two-input nano photonic AND gate, whose operation is based on optical near-field (ONF) interactions among three neighboring quantum dots (QDs), they improved the gate ON/OFF ratio by up to about 9 dB. To do this, Arash Karimkhani et al. have eliminated the possibility of direct ONF interaction between the inputs and output dots. Then, by adding another QD, as the second control dot to both existing and the modified two-input architectures, they proposed two new three-input nanophotonic AND gate schemes—one with direct ONF interaction between its input and output dots, and the other without such interaction. The

flip-flop was composed of two cross-coupled electrically pumped VCSOA inverters and used the principles of cross-gain modulation, polarization gain anisotropy, and highly nonlinear gain characteristics to achieve flip-flop functionality. They highlighted that, when integrated on chip, this type of all-optical flip-flop opens new prospects for implementing all-optical fast memories and timing regeneration circuits. Jingsheng Yang et al. presented a function-lock strategy for all-optical logic gate (AOLG) utilizing the cross-polarization modulation (CPM) effect in a semiconductor optical amplifier (SOA). By monitoring the power of logic light, the strategy realized controllable methods to capture OR and NOR functions and switch between them. The strategy had been successfully applied in experiment with 10-Gb/s not-return-to-zero (NRZ) signals, which had a high success-rate above 95% and ensures the high extinction ratio of result light above 11.4 dB. Every step in the strategy had definite numeric evaluation, which provides the potential of automatic implementation.

2. 2 OTDM BY MZI SWITCHING

D. Petrantonakis, P. Zakyntinos et. al demonstrated an all-optical four-wavelength 3R burst mode regenerator, operating error-free with 10-Gb/s variable length data packets that exhibit 6-dB packet-to-packet power variation. The circuit was implemented using a sequence of three integrated quadruple semiconductor optical amplifier-based Mach-Zehnder interferometric arrays. T. Ohara, H. Takara et. al provides the first report of 160-Gb/s optical time-division multiplexed transmission with all-channel independent modulation and all-channel simultaneous demultiplexing. By using a multiplexer and a demultiplexer based on periodically poled lithium neonate and semiconductor optical amplifier hybrid integrated planar light wave circuits, 160-km transmission was successfully demonstrated. Colja Schubert et al. investigated three interferometric all-optical switches based on cross phase modulation (XPM) in semiconductor optical amplifiers (SOAs), the semiconductor laser amplifier in a loop mirror (SLALOM) switch, the Mach-Zehnder interferometer (MZI) switch, and the ultrafast nonlinear interferometer (UNI) switch. Switching windows with different widths are measured under similar conditions for all three switching configurations’. J. M. Verdurmen highlighted all-optical time domain add-drop multiplexing for a phase modulated OTDM signal for the first time, to our knowledge. XIN Ming, et. al stated an alternative to label swapping, an all-optical label stripping scheme based on SOA-MZI. The stripping process is self-controlled without any synchronization process. Simulation results show that a high quality stripping can be achieved, with no more than 0.09dB of power fluctuation and 0.05dB of phase fluctuation in both stripped and remained label. A power contrast ratio of 28dB between the remained and residual stripped label, and 30dB signal-to-noise ratio (SNR) can be reached respectively.

Spälter et. al. stated transmission properties and high-speed switching technologies are presented for 160-Gb/s OTDM systems, which need to prove cost-effective in point-to-point link transmission and should offer time-domain routing capabilities in order to become a commercial reality. Parameters tolerance analysis shows that the stripping performance deteriorates little when considering the devices' imperfection in practice. The multi-hop simulation results also show that our scheme is applicable to large scale OPS networks. Hans-Georg Weber et al. presented ultrahigh-speed data transmission in optical fibers based on optical time division multiplexing (OTDM) transmission technology. Optical signal processing in the transmitter and receiver as well as the requirements on ultrahigh-speed data transmission over a fiber link were discussed. Finally, results of several OTDM-transmission experiments, including 160-Gb/s transmission over 4320 km, 1.28-Tb/s transmission over 240 km, and 2.56-Tb/s transmission over 160-km fiber link, were described.

2.3 Objectives

In this thesis, the research is carried out keeping in view of the following objectives.

1. To investigate the bit error rate and power control of a 4 X 40 Gbit/s optical time domain multiplexed system using Mach-Zehnder switching.
2. To investigate the optical logical operations of multiplexer and encoder using Mach-Zehnder Interferometer.
3. To investigate the bit error rate of FTTH at 40 Gbit/s by Mach-Zehnder Switching.

2.4 Research Outlines

After studying the basic introduction, literature survey, we define the objectives in chapter II.

In chapter III, we investigate the optical logical operations of multiplexer and encoder by Mach-Zehnder Interferometer at 10 Gbit/s.

In chapter IV, we practically investigate and validate bit rate and power control of the power normalize of the Mach-Zehnder switching at different four channels at different time shifts at same bit rate of 40 Gbit/s.

We finally discuss conclusions in chapter V and also the future work.

III IMPLEMENTATION OF OPTICAL ENCODER AND MULTIPLEXER USING MACH-ZEHNDER INTERFEROMETER

In this chapter a simple all-optical logic device, called Mach Zehnder Interferometer is composed by using a Semiconductor Optical Amplifier (SOA) and an optical coupler. This device is used for generating the logical functions (AND, XOR) and a multiplexer and an Encoder is obtained using this device in Optical Tree Architecture. The simulation of Encoder and Multiplexer is done at a rate of 10 Gbit/s and both are simulated for different input logical combinations. Simulations indicate that the device is suitable to operate at much higher bit rate and also for different logical entities.

3.1 INTRODUCTION

As we know in recent days the research in optical computing increasing day by day and many scientists working upon them, but in electronics computing the logical operations plays a very important role because they require less power, as they are digital circuits and as compared to the analog circuits, they are very flexible. But they have certain disadvantage also that they work up to limited frequency, but if we used that logic using optical instruments then it gives better stability, better speed and switching. In digital optical computing, optical interconnecting systems are the primitives that constitute various optical algorithms and architectures. High speed all-optical logic gates are key elements in next generation optical networks and computing systems to perform optical signal processing functions, such as all-optical label swapping, header recognition, parity checking, binary addition and data encryption. In the last few years, several approaches have been proposed to realize various logic gates using either high nonlinear fibers or semiconductor optical amplifiers (SOA). The SOA-based devices have the potential of monolithically integration, which offer the advantages of compactness, increased reliability and cost reduction. Up to now, most SOA based logic gates have been performed by employing cross gain modulation (XGM) and cross-phase modulation (XPM), which inevitably limit the operating speed of such devices due to the intrinsic slow carrier recovery time of SOA. Although the operating speed can be increased to 40Gb/s or higher with the use of a high-power continuous-wave holding beam [48] or different interferometer structures, the complexity and cost of the devices are increased. The request for high-speed all-optical signal processing has been posed by current and near-future optical networks in an effort to release the network nodes from undesirable latencies and speed limitations imposed by O/E/O conversion stages and to match the processing and transmission speeds. In this respect, a significant increase in research efforts towards the deployment of high-speed all optical signal processing technology, application concepts and demonstrations has been witnessed during the past few years. Semiconductor optical amplifier (SOA)-based, interferometric optical gates have appeared as the main-stream photonic signal processing units, exploiting their fast response for high-speed operation and taking advantage of the remarkable advance of hybrid and monolithic integration techniques for offering compact switching elements. To this end, single element, high-speed all-optical gates have been demonstrated as integrated devices in a number of laboratories across the world and have been developed as commercial products primarily for wavelength conversion and regeneration purposes.

3.2 MULTIPLEXER

A multiplexer or mux is a device that performs multiplexing; it selects one of many analog or digital input signals and outputs that into a single line. A multiplexer of 2^n inputs has n select bits, which are used to select which input line to send to the output.

Input A Input B Output

Table 3.1 Truth table of 2:1 Multiplexer

Input A	Input B	Output
0	0	Output 1
0	1	Output 2
1	0	Output 3
1	1	Output 4

3.3 ENCODER

An encoder is a device, circuit, transducer, software program and algorithm that convert information from one format, or code to another, for the purposes of standardization, speed, secrecy, security, or saving space by shrinking size. An encoder can be a device used to change a signal (such as a bit stream) or data into a code. The code serves any of a number of purposes such as compressing information for transmission or storage, encrypting or adding redundancies to the input code, or translating from one code to another. This is usually done by means of a programmed algorithm, especially if any part is digital, while most analog encoding is done with analog circuitry.

3.4 WORKING OF MULTIPLEXER

As we already discussed the MZI switch for all-optical logic so here the working of the optical tree using MZI based optical switches. There is a constant source of CW beam of which may be a laser source. The light signal that comes from CWLS can be taken as the incoming signal. The incoming light signal is incident on switch s1 first. Now we can obtain the light in different desired branches or sub branches by proper placing of control signals. Control signals are also light signals.

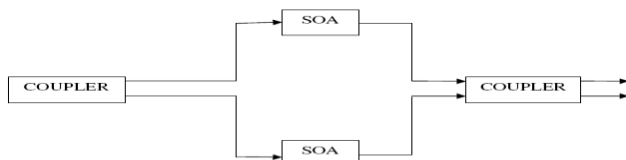

Fig 3.1 Optical logic using MZI switch

Case 1: When A = '0' and B = '0'

The CW light beam that comes from constant CWLS is incident on switch s1 first. As here A = '0', the control signal A is absent, that means only incoming light signal is present at s1. As per the switching principle discussed above, the light emerges through the lower channel and falls on switch s3 at C. Here the control signal B is absent. As signal B is absent so light finally comes out through lower channel of s3 and reaches output 1. In this case, no light is present at other outputs ports, so output port1 is one state and others are in zero state.

Case 2: When A = '0' and B = '1'

Light from the CW light source is incident on s1. As A = '0', the light beam emerges through the lower channel and falls on s3. At s3 the control signal B is present. In the presence of the control signal emerges through the upper channel of s3 and finally reaches to the output port 2. In this case light is only present in output port 2. Hence output port shows one state while others shows zero state.

Case 3: When A = '1' and B = '0'

The light from CWLS is incident on switch s1 first. As here A = '1', the control signal A is present. Because of that, the light emerges through the upper channel of s1 and falls on s2 at O. As B = '0', no control signal is present at B, that means

the light comes out from the lower channel of s2 to reach output port 3. So output port 3 is in one state and others are in zero state.

Case 4: When A = '1' and B = '1'

The light from CWLS is incident on switch s1 first. As here A = '1', the input control signal A is present. Because of that, the light emerges through the upper channel of s1 and falls on s2

at O. As B = '1', the control signal is present at B. Hence the light follows the upper channel of s2 to reach output 4. So output port 4 is in one state and the others is in zero state.

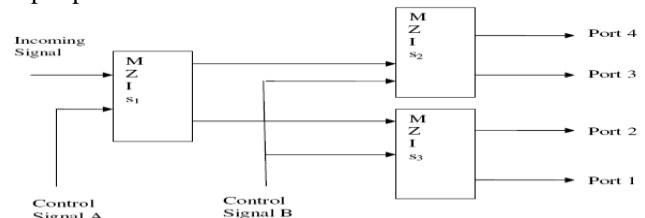

Fig 3.2 Block Diagram of Multiplexer

3.5 SIMULATION RESULTS AND DISCUSSIONS

This section of the thesis tells about the results of multiplexer and encoder using Mach-Zehnder Interferometer for all-optical logic. This project simulated in OPTSim 4.7.1 specified in Block mode which carries different components to generate the required circuit which gives the finally result.

3.6 SYSTEM DESCRIPTION OF MULTIPLEXER

This given below figure represents the schematic diagram of all-optical logic multiplexer by MZI switch. As it contains two sine wave generator having a frequency of 10 GHz which acts as signal generator followed by Direct Modulated Laser, as laser converts electrical signal into light signal and the output of both the lasers fed to optical coupler which contains two port named as bar port and cross port, now from each arm of the coupler fed to the MZI s1 MZIs2MZIs3.

Semiconductor optical amplifier and finally goes to the optical coupler as optical coupler followed by semiconductor optical amplifier is called Mach Zehnder Switch and different outputs of optical coupler fed to the Spectrum Analyzer. Signal Generator generates 10 GHz signal in sinusoidal form which is fed to the DM laser. Direct Mode Laser block shows simplified continuous wave (CW) laser. Its phase noise is taken into account by generating a signal generator whose FWHM (Full Width Half Maximum) is specified by Laser parameters. In model considered has 193.42 THz center emission frequency, 1550 nm wavelength, 1650 nm wavelength, 0dBm CW Power, 1mw CW Power, ideal laser noise bandwidth, 10 FWHM line width and laser random phase. Optical couplers, also referred to as opt couplers, are well known devices used to direct light from one light source to a light receiving member. An optical coupler is a passive device for branching or coupling an optical signal. Generally, a coupler is centralized by joining the two fibers together so that the light can pass from the sender unit to the two receivers, or else it can be made by juxtaposing the two "receiver" fibers which will then be aligned and positioned so as to be facing the "sender" fiber. Semiconductor optical amplifiers are amplifiers which use a semiconductor to provide the gain medium. The semiconductor optical amplifier is of small size and electrically pumped.



Optical Fiber Communication System Performance Using MZI Switching

The SOA has higher noise, lower gain, moderate polarization dependence and high nonlinearity with fast transient time. This originates from the short nanosecond or less upper state lifetime, so that the gain reacts rapidly to changes of pump or signal power and the changes of gain also cause phase changes which can distort the signals.

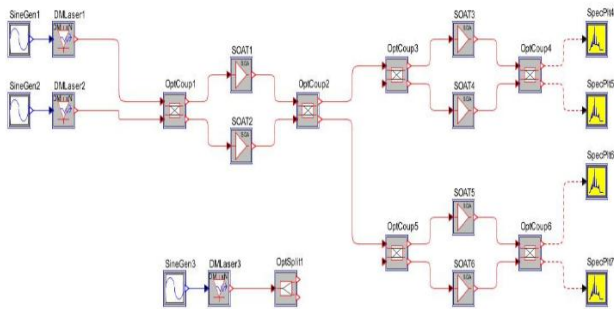

Fig 3.3 Schematic Diagram of Multiplexer (A = '1', B = '0')

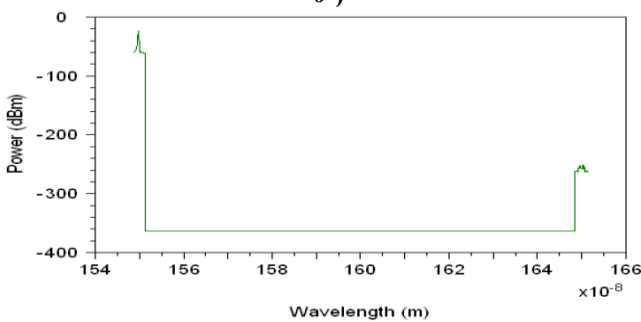
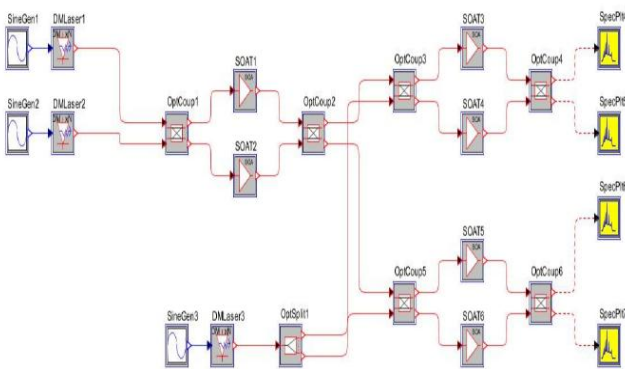

Fig 3.4 Wavelength spectrum of A = '1' & B = '0'

The above diagram shows the wavelength spectrum of the required logic at output port 1. As the spectrum that both the input signal and the control signal has the different wavelength so we have using for control signal is 1550 μm while the incoming signal consists the wavelength of 1650 μm so the it has maximum amplitude at wavelength of the control signal.

Case 1: When A = '1', B = '0', & EN = '1'

In this schematic diagram of the encoder three sine wave generators used to generate a sinusoidal pulse which directly fed to the direct modulated laser which is working at different wavelength for particular input signal, as this encoder having three input signal and an enable signal at different wavelength from the input signal and this enable signal is fed directly to the input arm of the coupler of MZI switch by beam splitter and providing the required logic.



Schematic diagram of encoder (A = '1', B = '1')

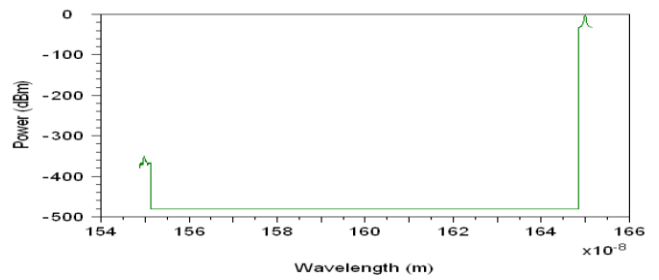

Wavelength spectrum of A = '1' & B = '1'

Case 2: When A = '1', B = '1' & EN = '1'

In this schematic as the last diagram represents two sinusoidal generator 10 GHz is followed by the Direct Mode laser which converts the electrical signal into optical signal or light signal

and the output of the laser is directly fed into the input arms of the coupler which passes the signal on bar port as depend upon the control signal. Here control signal is inserted into the circuit at the third level of the MZI switch as it consists of the two semiconductor optical amplifier at the both port of the optical coupler at the input and the same thing is followed at the output of the switch.

So here in this circuit control signal is applied to the all the inputs of the encoder but according to the principle of the MZI switch the input is received at the bar port of the coupler when control signal is present so as we applied two continuous signal at input of the both the laser so at first stage output is received at the bar port of the optical coupler 2 according to the so output of the optical coupler is fed to the input of the optical coupler 3 and at the same time third input also feeds to the input of the optical coupler 3 now again the same phenomena exists as control signal becomes the output of the optical coupler 2 and continuous wave signal treated as input so similarly same output of the optical coupler is fed to the input of optical coupler 5 and also same continuous signal is fed to the optical coupler 4 and now the output of the optical coupler 3 & 5 is processed properly.

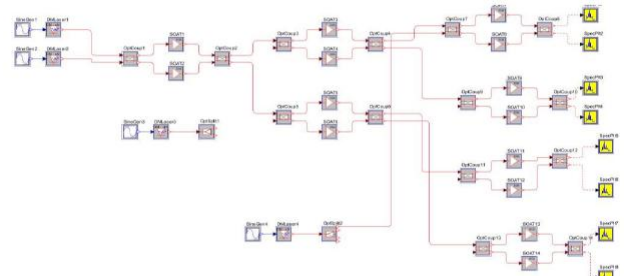

Schematic diagram of encoder (A = '1', B = '0', EN='1')

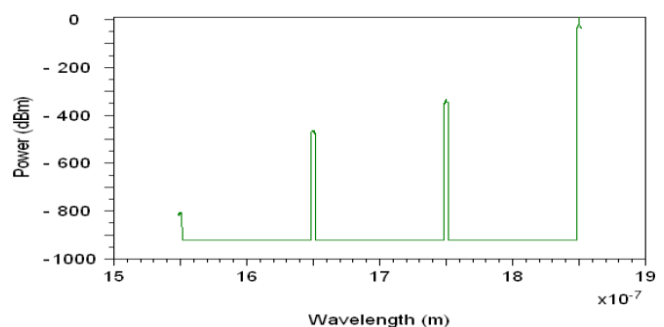

Wavelength spectrum of (A = '1' & B = '0', EN='1')

Now the output of the optical coupler 4 & 6 is fed to the one input arm of the optical fiber 7,9, 11, 13 and then the output from these required optical coupler are goes to the optical coupler 8, 10, 12, 14 through passing with the Semiconductor optical amplifier (SOA). At the both the port of the optical coupler spectrum analyzer is connected to measure the spectrum of the wavelength passing through the proper channel as we see earlier if we applied input at both the end of the coupler one of continuous and other is of control signal having a wavelength different from the continuous wave signal then output is received on only one port of the coupler so in that manner MZI switch works as a logical inverter so here EN is same as working as inverter so different spectrum received at the output of the optical coupler but the correct manner of output received at the spectrum analyzer 10 and it is shown at fig 2.10 which shows the wavelength spectrum of the received signal of all optical logic encoder in the form of '1'.

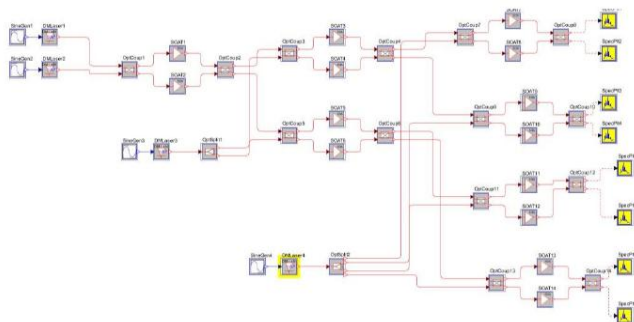

Fig 3.5 Schematic diagram of encoder (A = '1', B = '1', EN = '1')

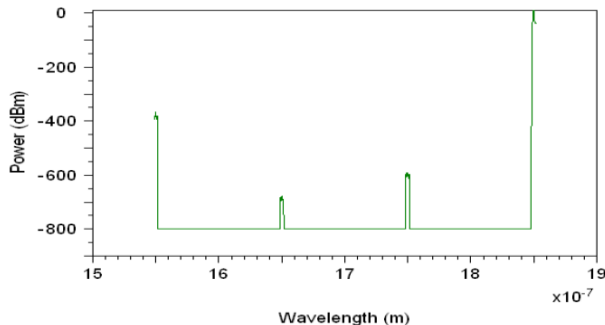

Fig 3.6 Wavelength spectrum of A = '1' & B = '1', EN = '1'

3.7 CONCLUSIONS

We have simulated an all-optical logic based Multiplexer and Encoder using MZ Interferometer. As different logic functions can be realized by simply adjusting two components i.e multiplexer and the encoder. The simulated method has the potential to operate at above 40 GB/s.

IV OPTICAL TIME DIVISION MULTIPLEXING USING MZI SWITCHING

Many lower-speed data streams can be multiplexed into one high-speed stream by means of Optical time division multiplexing (OTDM), such that each input channel transmits its data in an assigned time slot. The assignment is performed by a fast multiplexer switch (mux). The routing of different data streams at the end of the TDM link is performed by a demultiplexer switch (demux) and this demultiplexer is employed using MZI switch as it consists a semiconductor optical amplifier (SOA) and a optical coupler.

In this chapter four channel OTDM is simulated at 40 Gbit/s and further it is investigated the impact of the signal power, pulse width and control signal power on BER.

4.1 INTRODUCTION

The transmission capacity of an optical network could be extended in a simple way by installing additional fibers (space division multiplexing or SDM). Since this is very expensive, methods have been developed for a more efficient use of the available bandwidth in the existing fiber network. A first solution is to increase the bit rate in the network, which requires higher-speed electronics at the nodes of the network. The interleaving can be carried out on a bit-by-bit basis, like, or on a packet-by-packet basis. As data speeds become higher and higher, it becomes more difficult for the electronic parts (switches) in the system to handle the data properly. A. Cheng et al. Presented 40 Gb/s OTDM demultiplexing using an all-optical tunable delay line and an electro-absorption modulator. The continuous fiber-optic delay for channel selection is realized using four-wave-mixing and wavelength dependent group delay. Ken Morito et al. presented uniform output powers and high extinction ratios for a Mach-Zehnder interferometer type all optical switches with asymmetrically biased amplifiers and a phase shifter are found in a dynamic analysis for narrow control pulses and optimized switching windows. The performance of optical time division multiplexing (OTDM) system is limited by a complex combination of noise. In this paper we present a theoretical framework for the optical receiver in OTDM system based on the moment generation function. Jianfeng Zhang et. al. presented the proposed receiver model is showed to be more accurate in predicting the bit error rate (BER) performance than the former ones.[47] This problem can be overcome by routing the data through the optical domain, which is denoted as optical time division multiplexing (OTDM). The speed of the present day experimental OTDM systems is in the order of 10 Gb/s (single channel), and is mostly limited by the speed of the non-linear elements and the influence of physical effects like chromatic dispersion on the optical pulses in the employed fibers. Mach-Zehnder interferometers with integrated SOAs (SOA-MZI) are particularly attractive as high-speed optical gates. They feature low switching energy, high compactness and stability, as well as the potential for further optical integration. In this chapter we simulated four channel OTDM channels at speed of 40 Gbit/s for BER with pulse width, Control Signal Power.

4.2 TIME DIVISION MULTIPLEXING

TDM is digital process that allows several connections to share the high bandwidth of a link. Instead of sharing a portion of the bandwidth as in FDM, time is shared. Each connection occupies a portion of time in the link. TDM is a digital multiplexing technique for combining several low rate channels into one high rate one. In TDM, the data rate of the link is n times faster, and unit duration is n times shorter.

4.3 OPTICAL TIME DIVISION MULTIPLEXING

Electronic multiplexing at such speeds remains difficult and presents a restriction on the bandwidth utilization of a single-mode fiber link. An alternative strategy for increasing the bit rate of digital optical fiber system beyond the bandwidth capabilities of the drive electronics is known as optical time division multiplexing (OTDM). At the begin of the fiber optic data transmission the electrical digital channel signals have been electrically up multiplexed to the maximal aggregated data rate following a predefined data hierarchy. This aggregated electrical signal was converted electro-optically into the optical domain only for the transmission. For demultiplexing, the transmitted optical signal is converted into the electrical domain and demultiplexed in the electrical domain. The principle of this technique is to extend time division multiplexing by optically combining a number of lower speed electronic baseband digital channels. Figure shows the optical multiplexing and demultiplexing ratio is 1:4, with a baseband channel rate of required bit rate.

System can be referred to as a four channel OTDM system. The four transmitters in figure are driven by a common 40 GHz clock using quarter bit period time delays. Mode Locked semiconductor laser sources which produced short optical pulses were utilized at the transmitters to provide low duty cycle pulse streams for subsequent time multiplexing. Data was encoded onto these pulse streams using integrated optical MZ modulator which gave RZ transmitter outputs at 10 Gbit/s. these IO devices are employed to eliminate the laser chirp would result in dispersion of the transmitted pulses as they propagated within the single mode fiber, thus limiting the achievable transmission distance.

The four 40 Gbit/s data signals are combined in a passive optical power combiner but, in principle, an active switching element could be utilized. Although four optical sources are employed, they all emitted at the same optical wavelength within a tolerance of ± 0.2 nm and hence 40 Gbit/s data streams are bit interleaved to produce the 160 Gbit/s baseband components in a demultiplexer which comprised two levels. Again IO waveguide devices were used to provide a switching function at each level. At the first level the IO switch is driven by a sinusoid at 80 GHz to demultiplex the incoming 160 Gbit/s stream into 80 Gbit/s signals. Hence single wavelength 160 Gbit/s optical transmission is obtained with electronics which only required a maximum bandwidth of about 25 GHz, as return to zero pulses are employed.

4.4 DEMUX OPERATION USING MZI-SOA SWITCH

The MZI-SOA all optical switch is shown in Fig 5.4 It consists of two symmetric 2x2 multimode interferometer (MMI) splitters for dividing and combining data pulses, two couplers for introducing control pulses, two SOA's for providing phase shift, and a phase shifter (PS) for adjusting offset phases. The data signals injected from the input port are directed to the cross port or the bar port depending on the phase difference between the two SOA's. By injecting the control pulse 2 with a certain time delay and a proper energy difference against the control pulse 1, the slow phase change associated with the slow gain recoveries in two SOA's are completely eliminated. This gives rise to short switching windows. By adjusting the injection times of the two control pulses, one of the multiplexed data pulse signals can be

dropped to the bar port and the other signals can be transmitted to the cross state. Here counter propagating data and control pulses are assumed.

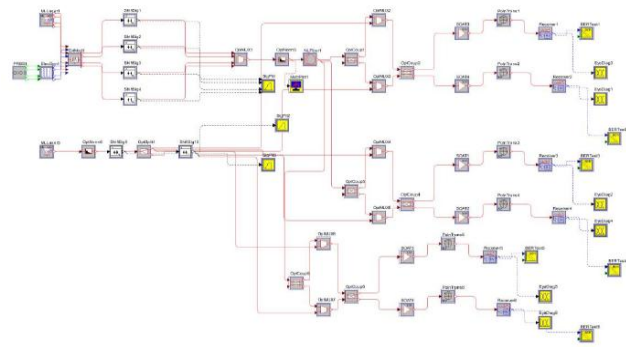

Fig 4.1 DEMUX using MZI switch

4.5 SIMULATION SETUP FOR OTDM

The particular system setup of OTDM is shown in figure (5.5). The component used in figure (5.5) are chosen from the Optsim Ver.4.7.0 component library palette and placed as per requirement in the design area of the Optsim editor. Then various simulation parameters are set. The transmitter comprises of a pseudo-random binary sequence or PRBS generator, mode locked laser diode, an electrical generator, four time shifting blocks, an optical MUX and an optical normalize. Multiple channels from a MLLD are RZ modulated with a different PRBS patterns. The PRBS block generates multiple pattern outputs, each different from the other and at same bit rate. All the channels from MLLD are at same wave length of 1650nm and of same power. Before being multiplexed together each consequent channel is delayed by 1/4 of time window in succession. Total power of all the channels is controlled by an optical normalize, which determines the average output power of OTDM signal before propagation over the fiber length. The OTDM signal travels over optical fiber of 100 km length and then it is de-multiplexed at the receiver end. The receiver consists of four identical SMZ switch (but with different time delays), each consists of a pulse train generator (with same repetition rate as the transmitter), optical normalizer block, pulse splitter and two time delay blocks and an SMZ switch with two output ports. The BER meter is connected at both output and reflected port to get the results. All the SMZ switch are connected at the output of the nonlinear fiber. Schematic Diagram of OTDM using MZI switching

4.6 RESULTS AND DISCUSSIONS

Synchronization between transmitter and receiver in OTDM is a critical issue for optimum performance of system. In this paper, the transmitter and the receiver has been synchronized by the addition of optical delay in the control signal. The optical delay is varied as an integer multiple of 1/4 of the pulse width within an expected bound. The pattern that emerges from such variation determines the optimum optical delay required for each channel. The effect of noise and distortion are well known in digital transmission. Noise causes bit errors at the decision gate of the receiver and distortion causes changes to the pulse shapes resulting in inter symbol interferences (ISI), which also produces bit errors. The major parameter in addition to bandwidth, which characterizes a digital optical link, is BER. So the effect of signal power (P_{signal}), control

signals power (Pcontrol), and pulse width on BER is investigated. Fig shows variation of BER with change in signal power. As mentioned previously optical normalizer controls the average output power of the multiplexed signal. The BER for channel 1 is in the range of 10^{-21} – 10^{-28} for Psignal values 5 and 10 dBm, respectively.

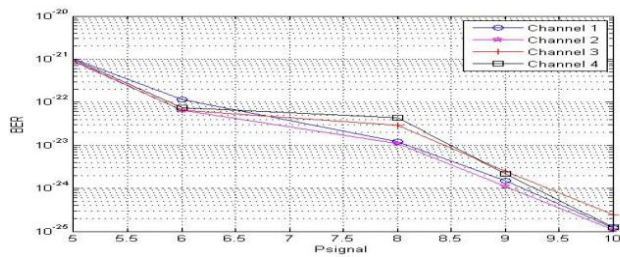

Fig 4.2 BER versus input signal power with dispersion

So it is observed that with the increase in signal power (Psignal) the BER is improved.

Similarly for channels 2 and 4 this variation is in the range of 10^{-22} – 10^{-25} and 10^{-22} – 10^{-25} for Psignal values of 5 and 10 dBm, respectively. It is interesting to note that BER for channels 2 and 3 is same for all the Psignal values. BER of an optical receiver is inversely proportional to SNR, which is in turn dependent on optical power of the signal. Thus BER decreases with increase in signal power.

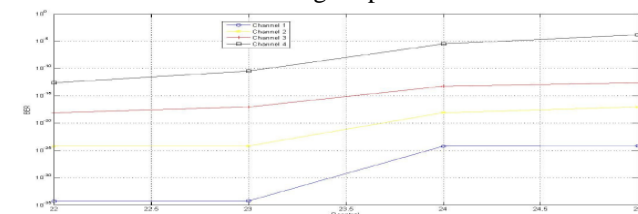

Fig 4.2 BER versus pulse width with dispersion

Further in Fig. 5.8 the effect of change in pulse width on BER is investigated. The pulse width of the input signal was varied within the bounds of $5e-12$ – $12e-12$ m and variation in BER was observed. As seen in the figure for channel 1 BER at $5e-12$ m is 10^{-140} and with increase in pulse width it decreases to 10^{-27} for pulse width $12e-12$ m. Once again there is an overlap in curves for channels 2 and 3 and the variation for BER is from 10^{-140} to 10^{-167} for above-mentioned variation in pulse width. For channel 4 the value of BER varies from 10^{-140} to 10^{-162} for above-mentioned variation in pulse width. The results indicate an improvement in receiver performance with increase in pulse width. This improvement can be attributed to reduction in pulse width distortion Shows a significant degradation in receiver performance when control signal power is increased gradually beyond 22 dBm.. Thus in case of channel 1 BER at 22dBm control signal is 10^{-35} and increases to 10^{-4} at 26 dBm. Channels 2 and 3 once again exhibit identical BER patterns and variation is in the

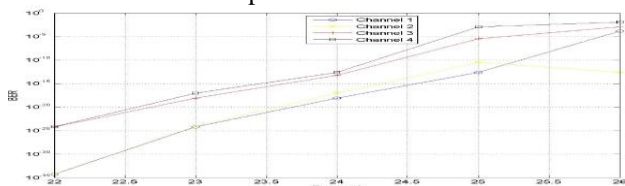

Fig 4.3 BER versus power control signal with dispersion

Range of 10^{-35} – 10^{-4} at 22 and 26 dbm, respectively. The variation in BER for channel 4 is in the range of 10^{-35} – 10^{-2} for the above-mentioned variations in control signal power. It is understood that principle of operations of an MZI switch is

based on interference between signals passing through the two legs of an MZI. The control signal affects a change in refractive index of semi-conductor material. The change in refractive index in turn introduces a phase shift in the input signal. It shows the effect of Pcontrol on BER with no dispersion for all the channels. The two signals interference at the output and the resultant output is dependent on their relative phase shifts. Thus, the signals may interfere either constructively or destructively. From the graphs it is evident that an increase in control signal beyond 22 dB m introduces a phase shift, which degrades the receiver performance and BER goes on increasing with increases in control signal power. Fig. 5.12 depicts eye diagrams for channel 1, at Pcontrol values of 22 and 26, respectively. There is degradation in decision level

offset values from 1.5×10^{-5} to 7×10^{-6} with increase in Pcontrol values from 22 to 26. This observation supports the conclusion drawn from BER versus Pcontrol signal.

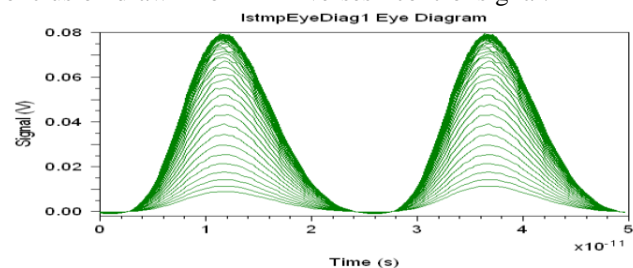

Fig 4.4 Eye Diagram

4.6 CONCLUSIONS

A 160-Gb/s OTDM transmission with all-channel modulation and all-channel simultaneous demultiplexing has been successfully simulated for the first time. The MUX and DEMUX using of MZI switch strictly maintain the delay time between adjacent channels and offer high-temperature stability because they are hybrid integrated on MZI switch; they will, therefore, be the keys to future OTDM transmission systems.

V. CONCLUSION AND FUTURE ASPECTS

5.1 CONCLUSION

In this thesis the scheme generating optical logic is implemented by MZ Interferometer as discussed in chapter 2 can be used for different purposes. This scheme can easily and successfully be extended and implemented for any higher number of input digits by proper incorporation of MZI based optical switches, vertical and horizontal extension of the tree and by suitable branch selection. Again the whole operation is parallel in nature, i.e. the results of different operations between the data are obtained at a time. Here we can implement the multiple instruction multiple data type operation nicely. Arithmetic operations can be conducted here between any two large-shaped data. The proposed one bit digital comparison scheme also successfully exploits non-linear material based tree structures for its operation. It is important to note that the above discussions are based on a simple model. In this simulation some walk parameter has to be considered such that dispersion,

polarization properties of the fiber, predetermined values of the intensities/wavelength of laser light for control and incoming signals, introduction of the filter, intensity losses due to the beam splitters/fiber couplers etc. As in this thesis the wavelength of the continuous wave of laser beam is 1550 μm and pulsed signal of wavelength of 1650 μm can be used as incoming and control signals, respectively. Intensity losses due to the couplers and splitters in the interconnecting stage may not create much trouble in producing the desired optical bits at the output as the whole system is a digital one and the output depends on the presence and absence of the light. In interconnecting stages fiber couplers can be used instead of the beam splitters.

Four channel 4 X 40 Gbit/s OTDM system (all channel) with a Mach-Zehnder modulator, MZI switching and a fiber length of 100 Km, has been experimentally and successfully verified. Experimental results reveal that BER decreases with increase in signal power and increase in pulse width. As in this thesis BER increases with increase in control signal power with dispersion in single mode fiber. It is also concluded that the performance of OTDM system can be improved using dispersion compensating fiber.

5.2 FUTURE ASPECTS

All-optical logic is recent research in the field of optical computing as this scheme also provides the idea of optical memory if we design a optical flip-flop which stores data as an optical pulse. As FTTH has many advantage over the all transmission techniques so, Providers could use ATM, SONET, Ethernet or Analog modulated RF carriers as their data link layer technology.

Since all users served by the same splitter – combiner on a curbside PON (and by the same Remote Node in an Active Star architecture) have to be served by the same data-link layer technology. FTTH infrastructure that is technologically and competitively neutral; where voice, video and data service providers can choose and deploy the technology of their choice to support the services they plan to offer. FTTH also provides additional services over it just like UWB (Ultra wide band), WCDMA, Radio over fiber, so many other services as network will use FTTH network as the interface for access network.

A focus has been put on the future-proof PON system having gigabit symmetry in bandwidth between the up- and downlinks. It has been shown that OCDMA is capable of providing a gigabit- or even multi gigabit-per-second for each user both in the up- and downlinks, and OCDMA over WDM PON could be one of the most promising system architectures that can break through the last/first mile bottleneck.

REFERENCES

1. Jitendra Nath Roy, "Mach-Zehnder interferometer based tree architecture for all-optical logic and arithmetic operations", *Optik Int Light Electron Opt.* (2009).
2. Koji Igarashi and Kazuro Kikuchi, "Optical Signal Processing by Phase Modulation and Subsequent Spectral Filtering Aiming at Applications to Ultrafast Optical Communication Systems", *IEEE journal of selected topics in quantum electronics*, Vol. 14, No. 3, May/June.

3. K. Uchiyama, H. Takara, K. Mori, T. Morioka, "160 Gbit/s all-optical time-division demultiplexing utilizing modified multiple-output OTDM demultiplexer (MOXIC)", *Electron. Lett.* 38 (2002) 1190–1191.
4. I. Shake, H. Takara, I. Ogawa, T. Kitoh, M. Okamoto, K. Magari, T. Ohara, S. Kawanishi, "160-Gbit/s full channel optical time-division de-multiplexer based on SOA- array integrated PLC and its application to OTDM transmission experiment", *IEICE Trans. Commun.* 53 (1) (2005) 20–2096.
5. H. Le-Minh, Z. Ghassemlooy, W.P. Ng, "Crosstalk suppression in an all-optical symmetric Mach-Zehnder (SMZ) switch by using control pulses with unequal powers, Proceedings of the International Symposium on Telecommunication 2005 (IST 2005)", Vol. 1, Shiraz, Iran, 2005, pp. 265–268.
6. M. Heid, S. Spalter, G. Mohs, A. Farbert, W. Vogt, H. Melchior, "160-Gbit/s demultiplexing based on a monolithically integrated Mach-Zehnder interferometer, Proceedings of the European Conference on Optical Communication (ECOC 2001)", Amsterdam, The Netherlands, September 30–October 4, 2001.
7. Haijiang Zhang, Pengyue Wen, and Sadik Esener, "Cascadable all-optical inverter based on a nonlinear vertical-cavity semiconductor optical amplifier", *Opt. Lett.* 32, 1884-1886 (2007).
8. Yanming Feng, Xiaofan Zhao, Li Wang, and Caiyun Lou, "High-performance all-optical OR/NOR logic gate in a single semiconductor optical amplifier with delay interference filtering, *Appl.*", *Opt.* 48, 2638-2641 (2009).
9. Jitendra Nath Roy and Dilip Kumar Gayen, "Integrated all-optical logic and arithmetic operations with the help of a TOAD-based interferometer device—alternative approach M. F. Lane, D. Z. Chen, and D. Kokkinos, Managing Fiber Connections in NGN and Applications, in National Fiber Optic Conference", OSA Technical Digest Series (CD) (Optical Society of America, 2007), paper NThA1.
10. Petrantonakis, P. Zakyntinos, D. Apostolopoulos, A. Poustie, G. Maxwell, and H. Avramopoulos, "All-Optical Four-Wavelength Burst Mode Regeneration Using Integrated Quad SOA-MZI Arrays", *IEEE PHOTONICS TECHNOLOGY LETTERS*, VOL. 20, NO. 23, DECEMBER 1, 2008.
11. Ludja Schubert, Jörn Berger, Stefan Diez, Hans Jürgen Ehrke, Reinhold Ludwig, Uwe Feiste, Carsten Schmidt, Hans G. Weber, Gueorgui Toptchyski, Sebastian Randel, and Klaus Petermann, "Comparison of Interferometric All-Optical Switches for Demultiplexing Applications in High-Speed OTDM Systems", *JOURNAL OF LIGHTWAVE TECHNOLOGY*, VOL. 20, NO. 4, APRIL 2002.
12. K. Kitayama, T. Kuri, J. J. Vegas Olmos, and H. Toda, "Fiber-Wireless Networks and Radio-over-Fiber Techniques, in Conference on Lasers and Electro-Optics/Quantum Electronics and Laser Science Conference and Photonic Applications Systems Technologies", OSA Technical Digest (CD) (Optical Society of America, 2008), paper CThR4.
13. R. Llorente, T. Alves, M. Morant, M. Beltran, J. Perez, A. Cartaxo, and J. Marti, "Optical Distribution of OFDM and Impulse-Radio UWB in FTTH Networks", in National 74 Fiber Optic Engineers Conference, OSA Technical Digest (CD) (Optical Society of America, 2008), paper JWA109.
14. Kuniharu Himeno, Shoichiro Matsuo, Ning Guan, and Akira Wada, Low-Bending-Loss Single-Mode "Fibers for Fiber-to-the-Home", *J. Light wave Technol.* 23, 3494- (2005)
15. D. Iazikov, C. Greiner, and T. W. Mossberg, "Apodizable Integrated Filters for Coarse WDM and FTTH-Type Applications", *J. Light wave Technol.* 22, 1402- (2004).
16. M. F. Lane, D. Z. Chen, and D. Kokkinos, "Managing Fiber Connections in NGN and Applications", in National Fiber Optic Engineers Conference, OSA Technical Digest Series (CD) (Optical Society of America, 2007), paper NThA1.