

# Simulation & Performance Analysis of Two Level AC-DC-AC Converter with IM

Kapil Jain, Ashish Garg, Rajkumar Rajoria, Pradyumn Chaturvedi

**Abstract-** The main features of multilevel Converter are the low harmonics content of output voltages and switches experience a voltage stress that is fraction of total dc bus voltage. In this paper, we discussed the AC-DC-AC converter performance with different load. First we describe, the Multilevel Inverter fundamental then the control technique for AC-DC converter, and Control technique for DC-AC converter. Performance of proposed converter is measured by different load at output end.

**Keywords:** SPWM, Multilevel Inverter, PI Controller,

## I. INTRODUCTION

Traditional high frequency pulse width modulation (PWM) Converter for motor drives have several problems associated with high frequency switching, which produce common mode voltages and high voltage change (dv/dt) rates to the motor windings. The main disadvantages of this technique are that a larger number of switching semiconductors are required for lower voltage systems and the small of voltage step must be supplied on the dc side either by a capacitor bank or isolated voltage topologies [5].

One of the significant advantages of multilevel configuration is the harmonics reduction in the output waveform without increasing switching frequency or decreasing the inverter power output. The output voltage waveform of a multilevel inverter is composed of number of levels of voltages, typically obtained from capacitor voltage sources. The main features of multilevel inverter are the low harmonics content of output voltages and switches experience a voltage stress that is fraction of total dc bus voltage[5][6].

## II. SIMULATION PARAMETER

The simulation of proposed converter was carried out with the help of MATLAB software (Ver.7.8; Mathworks Inc.) using simulink toolbox. The performance of these Converter was investigated under various conditions of load and output frequency. Following parameters are used for the simulation of two level AC-DC-AC converter drive system.

Three Phase AC Supply	-	25 KV, 50 Hz, 10 MVA
DC Link	-	7500 $\mu$ F
Line Side AC Filter	-	L = 20 mH, C = 100 $\mu$ F
Three Phase RL Load	-	R = 15 ohm, L = 24.2 m H
Series Inductance	-	R = 0.1 ohm, L = 20 $\mu$ H

Manuscript received on January, 2013.

**Kapil Jain**, Department of Electronics & Communication, Institute of Information Technology & Management (ITM Universe Campus), Gwalior, India.

**Ashish Garg**, Department of Electronics & Communication, Institute of Information Technology & Management (ITM Universe Campus), Gwalior, India.

**Rajkumar Rajoria**, Department of Electronics & Communication, Institute of Information Technology & Management (ITM Universe Campus), Gwalior, India.

**Pradyumn Chaturvedi**, Department of Electrical Engineering, SATI, Vidisha, India.

Three Phase Induction Motor 5.4 HP, 400 V, 50 Hz, 1430 rpm

## III. CONTROL TECHNIQUES

### (A) Control Technique for AC-DC Converter

The controller is the heart of converter operation and has been a subject of intense research in recent years. Conventionally, PI voltage and current controllers have been used in these converters. However, the conventional PI controller requires precise linear mathematical model of the system, which is difficult to obtain and fails to perform satisfactorily under parameter variations, nonlinearly, load disturbance.

A PI controller is used to control the converter output voltage  $V_o$ . The output of this controller,  $i_{Ld}^*$  is used as reference for an inner closed loop used to control the direct current  $i_{Ld}$ . The current in the q-axis,  $i_{Lq}$  is controlled by a similar loop with reference,  $i_{Lq}^* = 0$ , to obtain operation with unity power factor. It is to be emphasized that this method only controls the total dc bus voltage  $V_o$  and does not ensure the balance of capacitor voltages  $V_{c1}$  and  $V_{c2}$ . For proper converter operation,  $V_{c1} = V_{c2}$ . The current controllers deliver the reference values for the voltages in the d and q axis,  $V_d^*$  and  $V_q^*$  respectively. By using coordinates transformation, obtain  $V_{\alpha}^*$  and  $V_{\beta}^*$  in the stationary reference ( $\alpha, \beta$ ) frame. Voltages  $V_{\alpha}^*$  and  $V_{\beta}^*$  are used to derive the reference command input voltages  $V^*$  and its angle  $\theta$ . The modulator then generates the necessary control pulses for the rectifier switches [15].

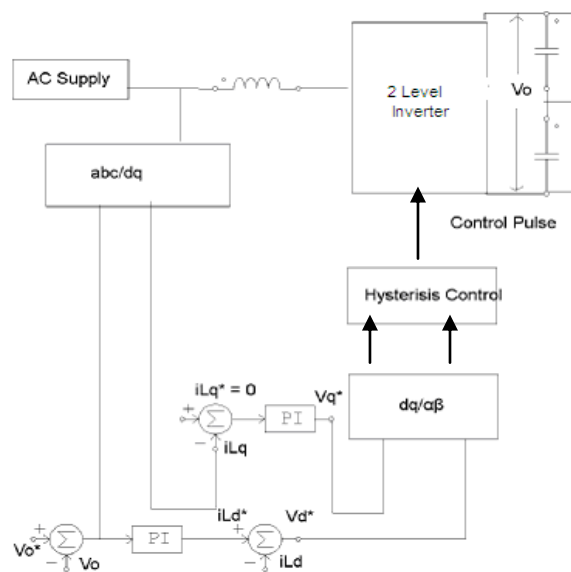


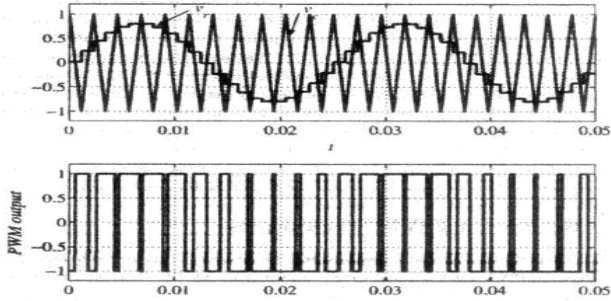
Fig.1 Control Block Diagram of AC-DC Converter

**(B) Control Technique for DC-AC Converter**

SPWM is the most widely used PWM technique for inverters of two and more levels. The basic principle of the bipolar PWM used in two level inverters is as follows. The reference signal ( $V_r$ ) which is generally sinusoidal is compared with the high frequency triangular wave ( $V_c$ ) of constant amplitude,  $V_c$ . At any instant of time the PWM output will be high (state +1) for  $V_r > V_c$  and output will be low (state-1) for  $V_r < V_c$ . The modulation index is defined as  $M_f = V_r / V_c$ . Where  $V_r$  is the peak of the reference and  $V_c$  constant, that is by varying  $M_f$ , the amplitude of the fundamental component of the output will be varied. Similarly by varying the frequency of  $V_r$ , the frequency of the fundamental component of the output waveform can be varied [13][10]. The pulse number, P is defined as

$$P = f_{sw} / F_s$$

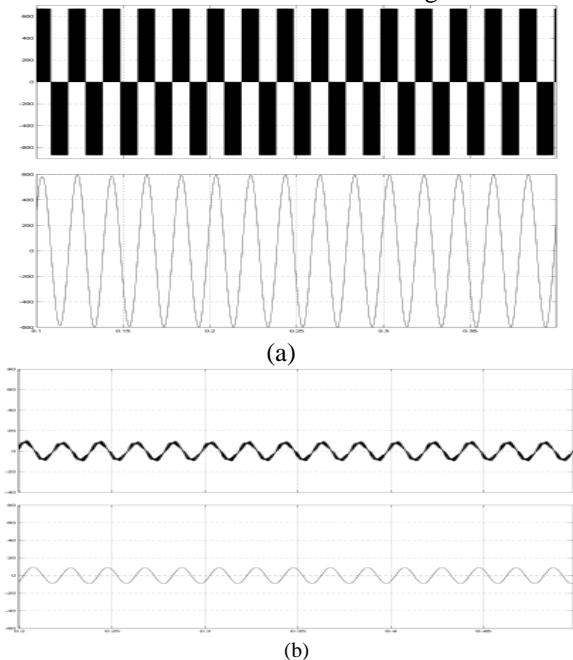
Where  $f_{sw}$  is the switching and  $F_s$  is the frequency of  $V_r$ . For two level inverters  $f_{sw} = f_c$ , where  $f_c$  is the frequency of  $V_c$ . For three phase inverters, the same carrier signal  $V_c$  is used for all the three phases and three reference signals which are phase displaced by  $2\pi/3$  radians are used for each of the phases. The above principle is easily extended to three level and other multilevel inverters.



**Fig. 2 SPWM: Bipolar Modulation for Two Level Inverter**

**IV. SIMULATION RESULT**

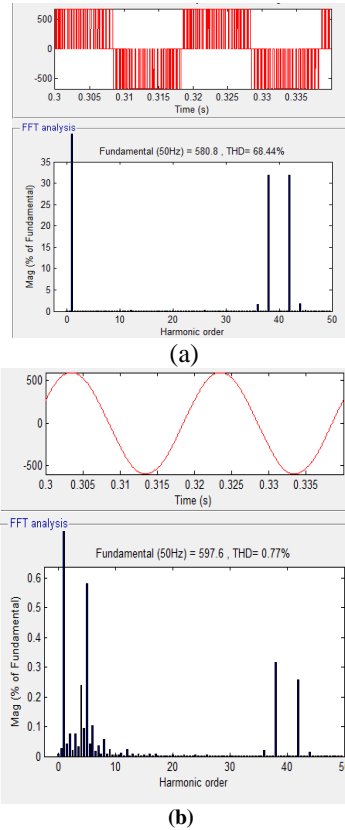
The voltage wave in the multilevel terminology is a two level waveform with a direct transition from the highest positive DC level to zero and then to the negative level.



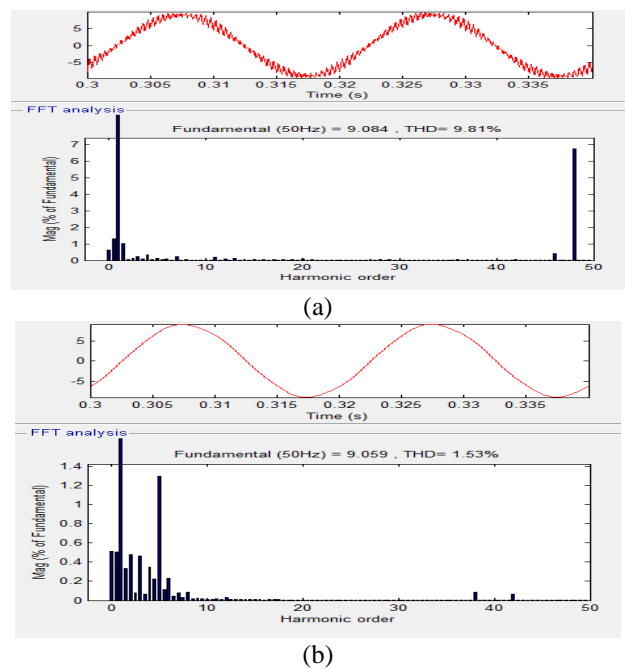
**Fig. 3 Simulation Result Of Two Level AC-DC-AC Converter with IM Load (a) Line Voltage (b) Line Current at 50 Hz**

Harmonics spectrums for voltage before and after filter are shown in fig 3 (a) & (b) respectively. It is clear from the fig 4 (a) & (b) spectrum, THD of the voltage, before filter is 68.44 % and it is 0.77 %, which is reduced after filter.

Harmonics spectrums for current for current, before and after filter are shown in fig 5(a) & (b) respectively. It is clear from the spectrum, THD of the current, before filter is 9.81 % and it is 1.53 % after the filter.

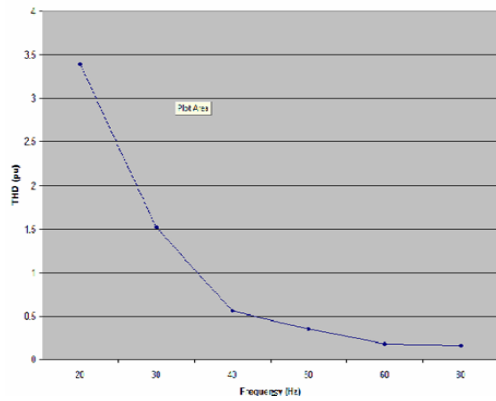


**Fig. 4 Harmonics Spectrum of the Voltage Wave at 50 Hz (a) Before Filter (b) Active Filter**



**Fig 5 It is clear from the figure that there is a substantial decrease in the THD as the frequency is increased.**

It is clear from the fig 6, when the frequency is increased; THD of IM load current is decreased.



**Fig 6 Effect of Inverter o/p Frequency on Load Current THD for IM Load**

## REFERENCE

1. J. S. Lai and F.Z. Peng "Multilevel Converters – A new breed of power converters" IEEE Trans. Ind Applicant, Vol. 32, May/June 1996.
2. Jose Roderiguez, Jih-Sheng Lai and Fang Zheng Reng, "Multilevel Inverters" A survey of topologies ,control, and applications " ,IEEE Trans. On Ind. Electronics, vol No. 4. August 2002.
3. A. Nabae, I Takashashi, and H. Akagi, "A new neutral –point clamped PWM inverter," IEEE Trans. Ind Application Vol. No. IA-17, PP 518-523, Sept/oc 1981.
4. P.K.Chaturvedi, S. Jain, Pramod Agrawal " Modeling , Simulation and Analysis of Three level Neutral Point CLAMPED inverter using Matlab/Simulink/Power System Blockst"
5. Bor-Ren Lin & Hsin – Hung Lu "A Novel Multilevel PWM Control Scheme of the AC/DC/AC converter for AC Drives"IEEE Trans on ISIE, 1999.
6. B. R. Lin & H- H Lu "multilevel AC/DC/AC Converter for AC Drives" IEEE Proceeding electronics Power application, Vol 146, No. 4, July 1999.
7. Y. Minari, K Shinohara, R. Ueda " PWM rectifier/voltage inverter without DC link components for induction motor drive" IEEE Proceeding-B, Vol 140, No. 6, November 1993.
8. DAI Bin " A new control scheme for voltage Source Inverter Without DC Link Capacitor Under Abnormal Input Voltage Conditions" IEEE Tran.2009.
9. K. Arab tehrani, H. Andriasioharana, I. Rasonarivo & F.M. Sargos " A Multilevel Inverter Model" IEEE Trans. 2008.
10. Siroroj Sirisukprasert, Jih- Sheng Lai & Tina – Hua Liu "Optimum harmonics Reduction With A wide Range Of Modulation Indexes for Multilevel Converters" IEEE Trans Ind Application Electronics , Vol 49 , No. 4, August 2002.
11. G.Bhuvaneshwari and Nagaraju " Multilevel inverters – a comaparative study" vol.51 No.2 march – april 2005.
12. Siroroj Sirisukprasert " Optimum harmonics reduction".
13. A. M. Massoud, S.J. Finney and B.W. Williams "Control Techniques for Multilevel Voltage Source Inverters" IEEE proce. 2003.
14. B.R. Lin and H.H. Lu "Multilevel AC/DC/AC converter for AC drives" IEE Proc.—Electr. Power Application, Vol. 146, No. 4, July 1999.