

Design of Ladner-Fischer and Beaumont-Smith Adders using Degenerate Pass Transistor Logic

Adilakshmi Siliveru, M. Bharathi

Abstract– In this paper, we propose Kogge-Stone and Brent-Kung parallel prefix adders based on degenerate pass transistor logic (PTL). Threshold loss problem are the main drawback in most pass transistor logic family. This threshold loss problem can be minimized by using the complementary control signals. These complementary control signals are obtained by 5-Transistor XOR-XNOR module. By using these complementary outputs we designed parallel prefix adders based on 10-Transistor full adder. Parallel prefix adders are used to speed up the binary addition and these adders are more flexible to perform addition of higher order bits in complex circuits. The transistor level implementation of parallel prefix adders based on degenerate PTL gives better performance compared to CPL and DPL pass transistor logic.

Keywords– Power Dissipation, degenerate, complexity, Threshold loss.

I. INTRODUCTION

Low power very large scale integration (VLSI) circuits are important for designing of high performance and portable devices. The high speed, small area and low cost are the main considerations of VLSI circuits. The importance of low power is increasing day by day because of changing trend, packaging and cooling cost, portable systems and reliability. In nanometre technology power has become the most important issue because of increasing transistor count, higher speed of operation and greater device leakage currents. Packaging and cooling cost is dependent on the power dissipation of the chip. Now a days there is a more demand on hand held or battery devices like cell phones, laptops and palmtops etc.,. As these devices are battery operated, battery life is primary concern. The reliability is mainly depends on the failure rates of the chip. These failure rates are due to changes in the temperature.

Every 10°C raise in temperature roughly double the failure rates. Reliability point of view low power design methodology is extremely important. The arithmetic circuits [2] are designed at transistor level based on different logic design styles. Those are conventional CMOS [3] logic; pass transistor logic, adiabatic logic and gate diffusion input. The details of pass transistor logic families are discussed in section II, and implementation of prefix adders are described in section III. The performance and results are discussed in section IV.

Manuscript received on March, 2013

Adilakshmi Siliveru, Electronics and Communication Engineering, Sree Vidyaniketan Engineering College, Tirupati, india,

M. Bharathi, Electronics and Communication Engineering, Sree Vidyaniketan Engineering College, Tirupati, India,

II. PASS TRANSISTOR LOGIC

Basically transistor is used as a switch. To realize the Boolean functions by using transistor as a switch is typically known as pass transistor logic. The advantages of pass transistor [10] based realization are ratio less, lower area due to smaller number of transistors and lesser power dissipation because of no static power and short circuit power dissipation. Some of the disadvantages of pass transistor logic are higher delay and multi threshold voltage drop. Pass transistor logic family [11] is used to overcome the limitations of pass transistor circuits. Some of the techniques are

1. Insertion of buffers to avoid long delay of a chain of pass transistor logic.
2. Use of swing restoration circuit to overcome multi-threshold voltage drop ($V_{out}=V_{dd}-V_{tn}$).
3. Use of dual rail logic to generate complementary control signals.

Complementary Pass Transistor Logic (CPL)

The complementary means it has both outputs i.e. f and \bar{f} . In this logic two networks are used to realizing both f and \bar{f} . At the output side we use two inverting buffers and two weak pMOS transistors. These inverting buffers are used to perform restoration logic levels at the output. The pMOS latches are used to perform swing restoration. The basic AND/NAND, OR/NOR and XOR/XNOR [8] gates implemented in CPL are shown in Figure 1.

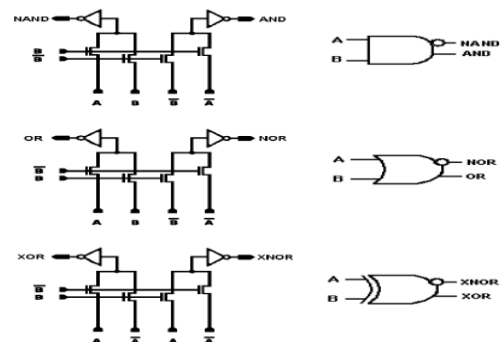

Figure 1. The basic AND/NAND, OR/NOR and XOR/XNOR gates implemented in CPL.

Double Pass Transistor Logic (DPL)

In double pass transistor [12] logic we are using both nMOS and pMOS transistors are used to design a circuit. Adding of pMOS transistor in parallel with nMOS will produce full swing at the output. The DPL configuration is different from static CMOS logic. The DPL is the modified version of CPL. In this logic extra transistor is not required for swing restoration. The basic AND/NAND, OR/NOR and XOR/

XNOR [9] gates implemented in DPL are shown in Figure 2.

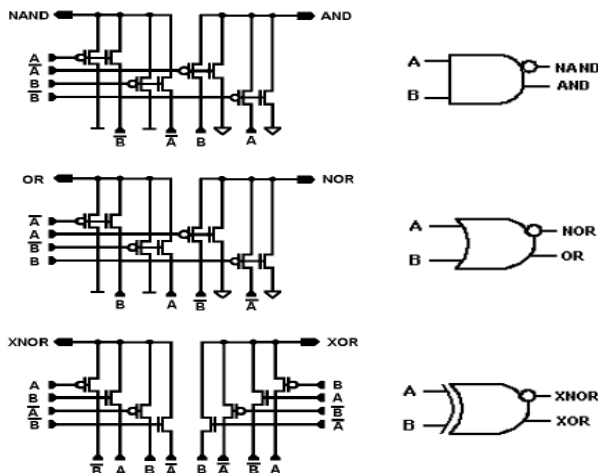

Figure 2. The basic AND/NAND, OR/NOR and XOR/XNOR gates implemented in DPL.

Degenerate Pass Transistor Logic

Most of full adder [4] designs are based on three module implementation i.e. XOR, sum, carry modules. The 4-Transistor XOR (XNOR) module [5] is used to design a pass transistor logic based full adder [13]. But this type of design raises severe threshold voltage loss problems. The signal degradation in the output causes signal degradation in the further modules. Finally the signal degradation in the circuit causes a multi-threshold loss problem at the output stage. These multi-threshold loss problems can be reduced by using complementary outputs. The complementary outputs are obtained by using 5-Transistor XOR-XNOR design. The design of degenerate 5-T XOR-XNOR module is shown in Figure 3.

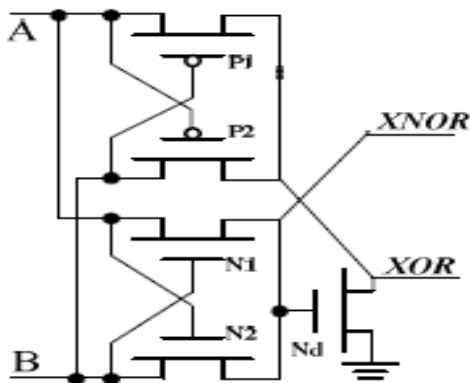

Figure 3. XOR-XNOR designs using 5 transistors.

With the availability of complementary control signals the selection of sum and carry modules [1] are more flexible to avoid the multi-threshold loss problems, the signal degradation in the full adder output is minimized and it is suitable for low v_{dd} applications. The design of degenerate 10-T PTL full adder design is shown in Figure 4.

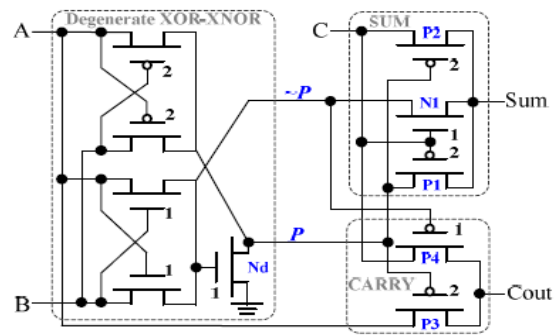

Figure 4. 10-T full adder design using degenerate PTL.

III. PROPOSED ADDERS

Parallel prefix adders

The parallel prefix adders [11] are more flexible and are used to speed up the binary additions. Parallel prefix adders [14] are obtained from Carry Look Ahead (CLA) structure. We use tree structure form to increase the speed [13] of arithmetic operation. Parallel prefix adders are fastest adders [4] and these are used for high performance arithmetic circuits in industries. The construction of parallel prefix adder [4] involves three stages

1. Pre- processing stage
2. Carry generation network
3. Post processing

Pre-processing stage

In this stage we compute, generate and propagate signals to each pair of inputs A and B. These signals are given by the logic equations 1&2:

$$P_i = A_i \text{ xor } B_i \dots\dots\dots (1)$$

$$G_i = A_i \text{ and } B_i \dots\dots\dots (2)$$

Carry generation network

In this stage we compute carries corresponding to each bit. Execution of these operations is carried out in parallel [4]. After the computation of carries in parallel they are segmented into smaller pieces. It uses carry propagate and generate as intermediate signals which are given by the logic equations 3&4:

$$CP_{ij} = P_{i:k+1} \text{ and } P_{kj} \dots\dots\dots (3)$$

$$CG_{ij} = G_{i:k+1} \text{ or } (P_{i:k+1} \text{ and } G_{kj}) \dots\dots (4)$$

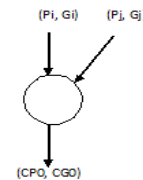

Figure 4. Carry operator.

The operations involved in this figure are given as:

$$CP_0 = P_i \text{ and } P_j \dots\dots\dots (3(i))$$

$$CG_0 = (P_i \text{ and } G_j) \text{ or } G_i \dots\dots\dots (3(ii))$$

Post processing

This is the final step to compute the summation of input bits. It is common for all adders and the sum bits are computed by logic equation 5&6:

$$C_{i-1} = (P_i \text{ and } C_{in}) \text{ or } G_i \dots\dots\dots (4)$$

$$S_i = P_i \text{ xor } C_{i-1} \dots \dots \dots (5)$$

Types of prefix adders are classified into

1. Ladner-Fischer prefix adder
2. Beaumont-Smith prefix adder

Ladner-Fischer prefix adder

Ladner-Fischer adder is a parallel prefix form carry look-ahead adder. A parallel prefix adder can be represented as a parallel prefix graph consisting of carry operator nodes. The time required to generate carry signals in this prefix adder is $O(\log n)$. It is a fastest adder design and common design for high performance adders in industry. The Ladner-Fischer [14] adder concept was developed by R. Ladner and M. Fischer, which they published in 1980. The better performances of Ladner-Fischer adder are minimum logic depth and bounded fan-out. But it has large area. The block diagram of 4-bit Ladner-Fischer adder is shown in Figure 6.

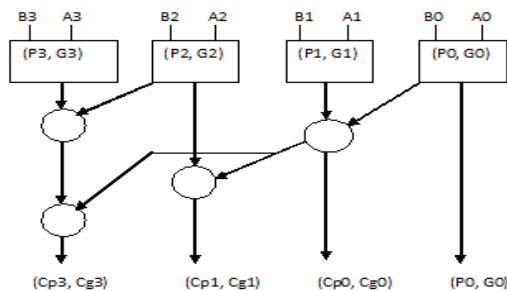

Figure 6. 4-bit Ladner-Fischer adder.

Transistor level implementation of SUM block and carry operator are shown in Figure 7&8.

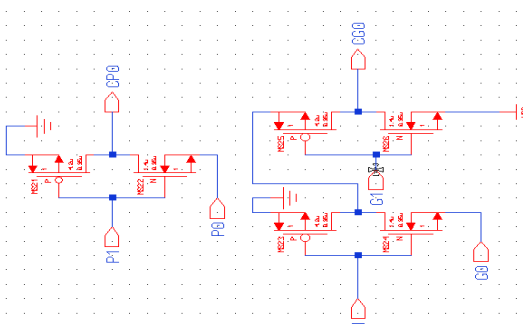

Figure 7. Transistor level implementation of carry operator.

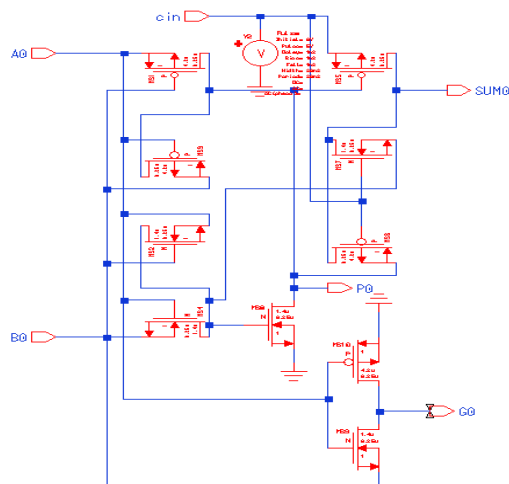

Figure 8. Transistor level implementation of SUM block.

Beaumont-Smith prefix adder

The Beaumont-Smith adder is a parallel prefix adder. Parallel prefix adders are special class of adders that are based on the use of generate and propagate signals. Simpler Beaumont-Smith adders was been proposed to solve the disadvantages of Ladner-Fischer adders. The cost and wiring complexity is greatly reduced. But the logic depth of Beaumont-Smith adders [15] increases to $2\log(2n-1)$, so the speed is lower. The block diagram of 4-bit Beaumont-Smith adder is shown in Figure 9.

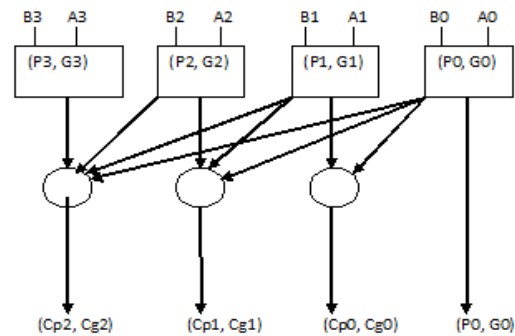

Figure 9. 4-bit Beaumont-Smith adder.

IV. SIMULATION RESULTS AND COMPARISONS

The various adders are simulated using SPICE code in Mentor Graphics tool. Adders are designed by using Design Architect in Mentor Graphics tool. The performance of proposed prefix adders in degenerate pass transistor logic are analyzed and compared. The prefix adder architecture is based on the implementation of propagate, generate and carry operator. Simulation results of Ladner-Fischer adder and Beaumont-Smith adder are compared in terms of DC power dissipation, memory size, number of components and number of steps computed.

Table 1. Comparison between Ladner-Fischer and Beaumont-Smith adders.

Parameter	Ladner-Fischer	Beaumont-Smith
Dc power dissipation(mw)	3.2356E ⁻⁰³	2.6422E ⁻⁰³
Memory size(bytes)	43524096	43511808
No. components	74	68
No. Of steps computed	1005	1009

Table 2. Simulation results of degenerate full adder

Parameter	Degenerate FA
Dc power dissipation(mw)	0.0
Memory size(bytes)	43294720
No. components	13
No. Of steps computed	334

Figure 11. Memory size comparison between Ladner and Beaumont prefix adders.

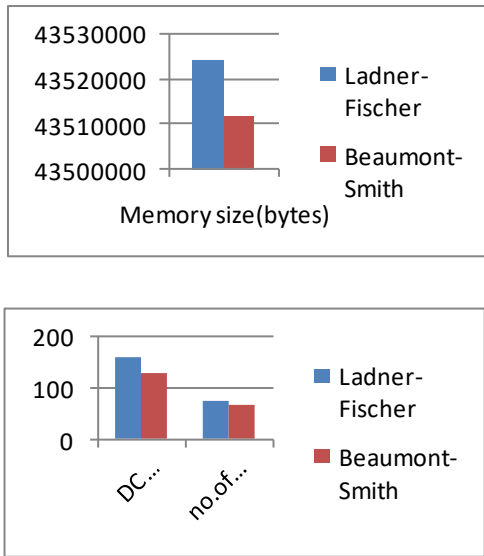

Figure 10. DC power dissipation and number of component comparison of Ladner and Beaumont prefix adders.

V. CONCLUSION

New approach of Degenerate pass transistor logic is used in the design of prefix adders to reduce the Threshold loss problem, power dissipation and signal degradation at the output. The transistor level implementation of prefix adders is simple, lesser power dissipation and high speed compared to other pass transistor logics. The tradeoffs of prefix adders are in terms of power dissipation and area. To design Beaumont-Smith adder it requires less number of carry-operators. So reduction in carry operator reduces tradeoffs of Beaumont-Smith adder compared to Ladner-Fischer adder. The simulated result shows that the proposed prefix adder greatly reduces in power dissipation as well as area.

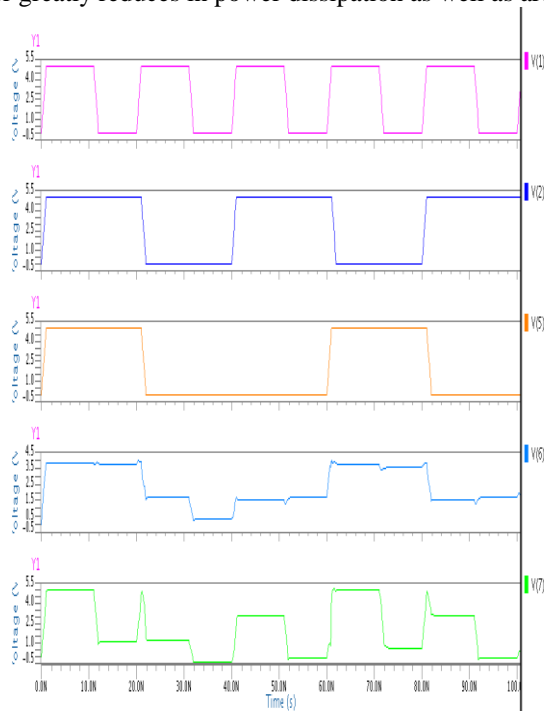

Figure 12. Simulated wave forms of degenerate full adder.

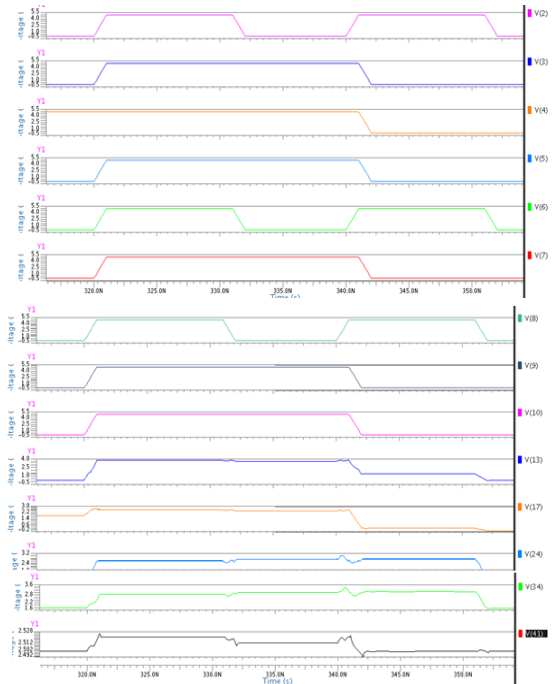

Figure 13. Simulated wave forms of Ladner-Fischer adder.

ACKNOWLEDGEMENT

S. Adilakshmi would like to thank Ms. M. Bharathi, Assistant professor ECE Department who had been guiding throughout the project and supporting me in giving technical ideas about the paper and motivating me to complete the work efficiently and successfully.

REFERENCES

- Jin-Fa Lin, Yin-Tsung Hwang and Ming-Hwa Sheu, "Low Power 10-Transistor Full Adder Design Based on Degenerate Pass Transistor Logic," IEEE Trans. VLSI, vol. 13, no. 6, pp. 686–695, Jun. 2012.
- C.-H. Chang, J. Gu, and M. Zhang, "A review of 0.18-um full adder performances for tree structured arithmetic circuits," IEEE Trans. VLSI, vol. 13, no. 6, pp. 686–695, Jun. 2005.
- D. Radhakrishnan, "Low-voltage low-power CMOS full adder," IEE Proc. Circuits Devices Syst., vol. 148, no. 1, pp. 19–24, Feb.2001.
- Y. Choi, "Parallel Prefix Adder Design," Proc. 17th IEEE Symposium on Computer Arithmetic, pp 90-98, 27th June 2005
- H. T. Bui, Y. Wang, and Y. Jiang, "Design and analysis of low-power 10-transistor full adders using XOR–XNOR gates," IEEE Trans. Circuits Syst. II, Analog Digit. Signal Process. vol.49, no. 1, pp. 25–30, Jan. 2002.
- J.-F. Lin, Y.-T. Hwang, M.-H. Sheu and C.-C. Ho, "A novel high speed and energy efficient 10-transistor full adder design," IEEE Trans. Circuits Syst. I, vol. 54, no. 5, pp. 1050–1059, May 2007.
- Y. Jiang, Al-Sheraidah, A, Y. Wang, Sha, E, and J. G. Chung, "A novel multiplexer-based low-power full adder," IEEE Trans. Circuits Syst. II, Analog Digit. Signal Process. vol. 51, pp.345–348, July 2004.
- J. Wang, S. Fang, and W. Feng, "New efficient designs for XOR and XNOR functions on the transistor level," IEEE J. Solid-State Circuits, vol. 29, pp. 780–786, July 1994.
- J.-B. Kim, et al., "New circuits for XOR and XNOR circuits," International Journal of Electronics, vol. 82, pp. 131–143, Feb.1997.
- K. Taki, A survey for pass-transistor logic technologies — Recent researches and developments and future prospects, Proceedings of the ASP-DAC'98 Asian and South Pacific Design Automation Conference, Feb. 1998, pp. 223–226
- P. Buch, A. Narayan, A.R. Newton, A. Sangiovanni-Vincentelli, Logic synthesis for large pass transistor circuits, Proceeding of the IEEE International Conference on Computer-Aided Design (ICCAD), November 1997, pp. 633–670.

12. A. Jaekel, S. Bandyopadhyay, G.A. Jullien, Design of dynamic pass transistor logic using 123 decision diagrams, IEEE Trans. on CAS-I: Fundamental Theory and Applications 45 (11) (1998) 1172–1181.
13. K. Yano, Y. Sasaki, K. Rikino, K. Seki, Top-down pass-transistor logic design, IEEE Journal of Solid-State Circuits 31 (6) (1996) 792–803.
14. R. Ladner and M. Fischer, “Parallel prefix computation,” Journal of ACM. La Jolla, CA, vol.27, no.4, pp. 831-838, October 1980.
15. Andrew Beaumont-Smith and Cheng-Chew Lim, “Parallel Prefix Adder Design”, Department of Electrical and Electronic Engineering, the University of Adelaide, 2001.

AUTHORS PROFILE



S. Adilakshmi completed her B.Tech in Electronics and Communication Engineering from Kandula Obula Reddy Memorial College of Engineering, Kadapa, Andhra Pradesh, India in 2011. She is now pursuing her Master of Technology (M.Tech) in VLSI at Sree Vidyanikethan Engineering College, Tirupati, Andhra Pradesh, India. Her interest includes Digital Design, VLSI Testing.



Ms. M. Bharathi, M.Tech., is currently working as an Assistant Professor in ECE department of Sree Vidyanikethan Engineering College, Tirupati. She has completed M.Tech in VLSI Design, in Satyabhama University. Her research areas are Digital System Design, VLSI Signal Processing.