

Three Phase to Three Phase Direct Matrix Converter using SPWM Technique

Sharon D. Ronald, A. Sheela, S. Josephin Mary

Abstract— The principle of three phase SPWM AC-AC matrix converter using 9 bidirectional switching devices is explained. IGBT-power diode combination is used as main power switching device. Constant voltage and frequency sinusoidal supply voltage can be converted to variable voltage and frequency voltage using this converter. The working is described based on the working three phase to single phase matrix converter. MATLAB/ Simulink software is used for the simulation. The operation is analyzed for various modulation indexes and input voltages. The results are compared and the optimum condition for favorable operation is obtained.

Index Terms— sinusoidal pulse width modulation, ac to ac converter, matrix converter.

I. INTRODUCTION

The matrix converter is a direct AC-AC converter consists of an array of bidirectional switches which connects the power supply directly to the load without using any dc link or large energy storage elements [1].

The matrix converter has several advantages over traditional rectifier-inverter type power frequency converters. It provides sinusoidal input and output waveforms, with minimal higher order harmonics and no sub harmonics; it has inherent bi-directional energy flow capability; the input power factor can be fully controlled. Last but not least, it has minimal energy storage requirements, which allows to get rid of bulky and lifetime- limited energy-storing capacitors.

But the matrix converter has also some disadvantages. First of all it has a maximum input output voltage transfer ratio limited to 87 % for sinusoidal input and output waveforms. It requires more semiconductor devices than a conventional AC-AC indirect power frequency converter, since no monolithic bi-directional switches exist and consequently discrete unidirectional devices, variously arranged, have to be used for each bi-directional switch. Finally, it is particularly sensitive to the disturbances of the input voltage system [2],[3].

In 1976 Gyugyi and Pelly introduced the first principle of a matrix converter [4],[5]. In 1980 the matrix converter was introduced in mathematical form by Venturini and switches is the main drawback of this converter [8]. The developments in intelligent and soft commutation techniques given new momentum to the research in this area. The different modulation and control strategies that can be applied to MCs are explained in.

Manuscript received April, 2013.

Sharon D. Ronald, PG Scholar, Department of Electrical and Electronics Engineering, Kongu Engineering College, Erode, India..

A. Sheela, Assistant Professor (Senior Grade), Department of Electrical and Electronics Engineering, Kongu Engineering College, Erode, India.

S. Josephin Mary, PG Scholar, Department of Electrical and Electronics Engineering, PSG College of Technology, Coimbatore, India.

II. PRINCIPLE OF THREE PHASE MATRIX CONVERTER

The topology and the theoretical analysis in terms of mathematical equations are described based on theoretical and simulated waveforms as follows.

A. The Topology

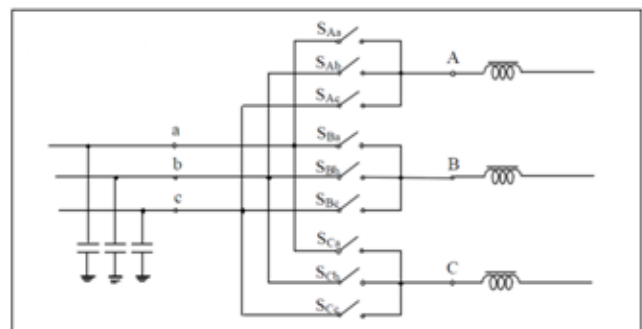

Fig.1. circuit scheme of a three phase to three phase matrix converter

The input terminals of the converter are connected to a three phase voltage-fed system, usually the grid, while the output terminal are connected to a three phase current- fed system, like an induction motor might be. The capacitive filter on the voltage- fed side and the inductive filter on the current- fed side represented in the scheme of Fig.1 are intrinsically necessary. Their size is inversely proportional to the matrix converter switching frequency.

It is worth noting that due to its inherent bi-directionality and symmetry a dual connection might be also feasible for the matrix converter: a current- fed system at the input and a voltage- fed system at the output.

With nine bi-directional switches the matrix converter can theoretically assume 512 (2^9) different switching states combinations. But not all of them can be usefully employed. Regardless to the control method used, the choice of the matrix converter switching states combinations (from now on simply matrix converter configurations) to be used must comply with two basic rules. Taking into account that the converter is supplied by a voltage source and usually feeds an inductive load, the input phases should never be short-circuited and the output currents should not be interrupted. From a practical point of view these rules imply that one and only one bi-directional switch per output phase must be switched on at any instant. By this constraint, in a three phase to three phase matrix converter 27 are the permitted switching combinations.

B. The bidirectional switch realization and commutation

A first key problem is related to the bi-directional switches realization. By definition, a bidirectional switch is capable of conducting currents and blocking voltages of both polarities,



depending on control actual signal. But at present time a true bi-directional switch is still not available on the market and thus it must be realized by the combination of conventional unidirectional semiconductor devices. Fig.2. shows different bi-directional switch configurations which have been used in prototypes.

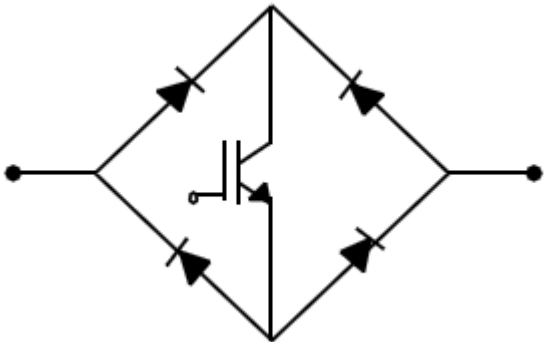

Diode bridge with a single IGBT

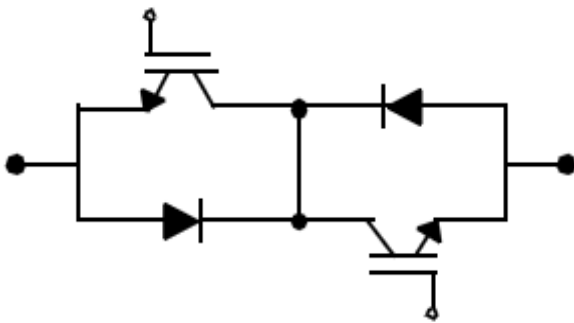

Two anti parallel IGBT with series diodes

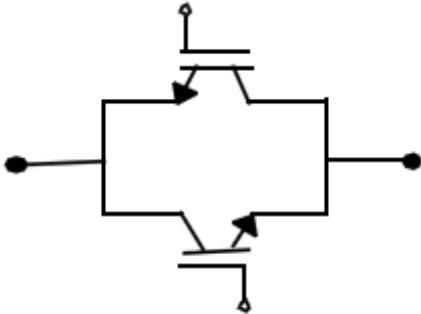

Two anti parallel NTC IGBTs with reverse blocking capabilities

Fig.2 different bidirectional switch combinations

Another problem, tightly related to the bi-directional switches implementation, which has represented a main obstacle to the industrial success of the matrix converter, is the commutation problem. The commutation issue basically rises from the absence, in the matrix converters, of static freewheeling paths. As consequence it becomes a difficult task to safely commutate the current from one bi-directional switch to another, since a particular care is required in the timing and synchronisation of the switches command signals.

III. ADVANTAGES AND LIMITATIONS OF MATRIX CONVERTERS

The advantages of matrix converters are listed below

- 1) provides direct ac-ac conversion thus eliminating the need for reactive energy storage elements.

- 2) The DC link components are bulky and their elimination can drastically reduce the size/footprint of the Matrix Converter system.
- 3) Elimination of the DC link provides the opportunity for integration of all switch cells of the Matrix Converter within one semiconductor building block (module). The semiconductor building block can be fabricated as a power integrated circuit (power IC) with significant potential for cost reduction. Furthermore, the IC can also incorporate gating/protection circuits and consequently further add to the reliability, facilitate interface to the control platform, provide modularity and more importantly reduce size and weight.
- 4) The Matrix Converter provides an inherent four quadrant operation.
- 5) It provides independent control of the output voltage magnitude, frequency and phase angle and operation at lagging, unity or leading power factor.

Some of the limitations of matrix converters include-

- 1) Higher number of unidirectional switches can result in a higher switching loss and a lower overall efficiency.
- 2) Inherently, the lack of a DC link in the Matrix Converter indicates that there is a stronger coupling between the two ac sides of the Matrix Converter. Therefore, more elaborate control strategy may be required to minimize mutual interactions between the ac sides.

IV. WORKING OF THREE PHASE TO THREE PHASE DIRECT MATRIX CONVERTER

A Three-Phase to Three-Phase Matrix Converter is structured based on the Three-Phase to Single-Phase Matrix Converter. If three sets of the single-output Matrix Converters are connected to the same input voltages, a three-output Matrix Converter is constructed.

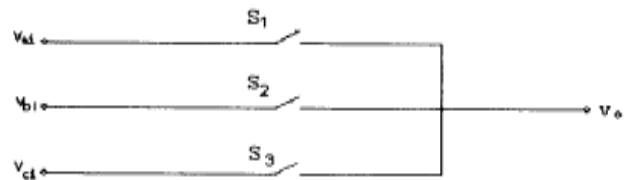

Fig.3. Representation of three phase to single phase matrix converter

A Three Phase to Single-Phase Matrix Converter is shown in Fig. 3. The converter is composed of three bidirectional switches S1, S2 and S3. Each switch connects the output line to an input phase. To avoid short-circuit in the source-side (three-phase side) and current interruption in the load side (single-phase side), only one switch can and must be on at any time. The switches are turned on and off in a sequential and cyclical pattern. For the j th switching period, if t_1^j , t_2^j and t_3^j are the on-time intervals of S1, S2 and S3, respectively, we have,

$$t_1^j + t_2^j + t_3^j = T_m = 1/f_m$$

where T_m is the switching period. The output line is connected to an input voltage for a specific period of time. Thus, the output voltage is a concatenation of segments of the three input voltages. Therefore, the output voltage waveform $V_o(t)$ is a function of the three input voltages $V_{ai}(t)$, $V_{bi}(t)$ and $V_{ci}(t)$. In general, the output



voltage harmonic components depend also on the input frequency and the switching strategy.

The working is started assuming that S1 is initially on when S2 and S3 have been off. The Circuit operation is analyzed for a complete switching sequence assuming that St is on followed by commutation to S2, then to S3 and finally back to S1.

A Three-Phase to Three-Phase Matrix Converter is structured based on the Three-Phase to Single-Phase Matrix Converter. If three sets of the single-output Matrix Converters are connected to the same input voltages, a three-output Matrix Converter is constructed. The structure of a three-phase to three-phase Matrix Converter is shown in Fig. 4. The converter consists of nine bidirectional switches (Saa, Sba, and Scc) whose operations are coordinated by a number of switching functions.

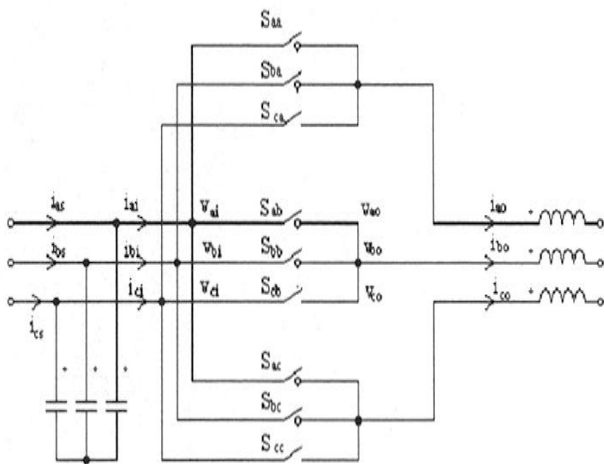

Fig 4. Representation of a three phase to three phase Matrix converter

The Matrix Converter can represent a symmetric electrical system, if a proper switching strategy is used. Sab, Sbb and Sbc must be switched with a phase delay of 120° with respect to Saa, Sba and Sca. Also, a 240° phase delay must be considered for the switches Sac, Sbc and Scc to get a three phase output.

V. SIMULATION RESULTS

The simulation can be done according to the following steps.

- The gate pulses can be generated by comparing three phase sinusoidal signals with high frequency triangular carrier wave.
- The input three phase supply should be referred so that the line voltage which is maximum at particular time can be identified.
- According to the identified line voltage switching pulses can be distributed to the switches.
- Switches connected to the same input phases should be fired with 120° phase shift with respect to each other.

Simulations were done using MATLAB/Simulink software package. The three phase matrix converter is constructed using 3 three phase to single phase matrix converters. The bidirectional switch used here is two IGBTs connected back to back. The output voltage and current waveforms were observed for a resistive load of R 10Ω and an input frequency of f =50 Hz.

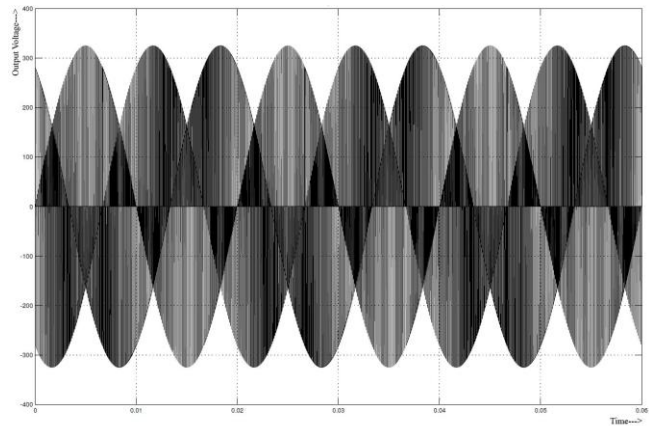

Fig.5. Output voltage waveform for modulation index=0.8

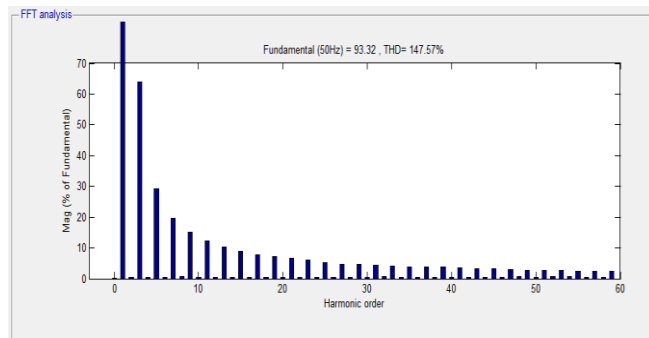

Fig.6 output voltage THD spectrum

Fig.6 shows the output voltage total harmonic distortion spectrum for modulation index of 0.8 without filter. By using filters in the output, harmonics can be reduced.

VI. CONCLUSION

Thus in this paper the basic principles of three phase to three phase direct matrix converter is explained in detail. The working is based on the working of three phase to single phase matrix converters. The different switching combinations that can be used in matrix converters were explained. The simulation results were shown. The THD spectrum is also shown. From these results we can be brought these data to application for the single phase induction motor drive system for any applications.

REFERENCES

- [1] Huber et al, "Space vector modulated three phase to three phase matrix converter with input power factor correction", *IEEE Trans. IA*, 1995, 11(3), pp. 1234-1246.
- [2] Alesina, M. Venturini, "Analysis and Design of Optimum-Amplitude Nine-Switch Direct AC-AC Converters", *IEEE Transactions on Power Electronics*, Vol. 4, no. 1, pp.101-112, January 1989.
- [3] Casadei, G. Grandi, G. Serra, A. Tani, "Space vector control of matrix converters with unity input power factor and sinusoidal input/output waveforms," *Proceedings of IEEEPE'93*, Vol. 7, pp. 170-175, 1993.
- [4] L. Gyugyi and B. R. Pelly, *Static Power Frequency Changers: Theory, Performance, and Application*, John Wiley & Sons, 1976.
- [5] H. Miller, "A note on reflector arrays (Periodical style—Accepted for publication)," *IEEE Trans. Antennas Propagat.*, to be published.
- [6] B.R. Pelly, "Thyristor Phase-Controlled Bridge Cycloconverters", New York, Wiley, 1971.
- [7] Alesina and M. Venturini, "Solid State Power Conversion: A Fourier Analysis Approach to Generalize Transfer Synthesis", *IEEE Transactions on Circuit and Systems*, vol. CAS-28, No.4, pp.319-330., April 1981.
- [7] P.D. Ziogas, S.I. Khan, and M.H. Rashid, "Some Improved Forced

- Commutated Cycloconverter Structure " *IEEE Trans. Industry Application*, vol.IA-21, pp.124 2-1253, Sept./Oct. 1985.
- [8] Yang Xi-Jun, Lei Huai-ang, Cao Yi-long, GPng ou-min, "Realization of Matrix Electric Power conversion with Practicality", *PCC-Osaka* 2002, pp.1182-11 7.
- [10] P. D. Ziogas, S. I. Khan, and M. H. Rashid, "Analysis and design of Forced Commutated Cycloconverter structures with Improved Transfer Characteristics",. *IEEE Trans. Industry Application*, vol. IE-33, NO.3, August 1986
- [11] P. C. Loh, R. Rong, F. Blaabjerg, and P. Wang "Digital carrier modulation and sampling issues ,of matrix converters", *IEEE Trans. Power Electron.*, vol 4, no. 7, pp. 1690-1700, July 2009.
- [12] Y. D. Yoon, and S. K. Sui, "carrier-based modulation technique for matrix converter", *IEEE Tran. Power Electron.*, vol. 21, no. 6, pp. 1691-1703, NoV. 2 6.
- [13] Sato, J. Itoh, H. Ohguchi, A. Odaka, andI.H.Mine, "An improvement method of matrix converter, drives under input voltage disturbances", *IEEE Trans. Power electron.*, vol. 22, no. 1, pp. 132-138, January 2007.
- [14] C. Liu, B. Wu, N. R. Zargari, D. Xu, ant J.Wang, "A novel three-phase three-leg ac/ac converter using nine IGBTs", *IEEE Trans. Power Electron.*, voL 2 , o. 5, pp. 1151-1160, May 2009.
- [15] R. Vargas, U. Ammann, and J. Rodrigudz, predictive approach to increase efficiency and reduces switching losses on matrix converters", *IEEE trans, Power Electron.*, vol. 24, no. 4, pp. 894-902, April 0 9.
- [16] J. I. Itoh, and K. I. Nagayoshi, "A new bidirectional switch with regenerative snubber to realize. A simple series connection for matrix converters", *IEEE Tran. Power Electron.*, vol. 24, no. 3, pp. 822-829, March2009 .



Sharon D. Ronald is currently pursuing M.E. Degree in Electrical and Electronics Engineering specialized in Power electronics and Drives from Kongu Engineering College, Erode, Tamil Nadu, India. He completed B.E. Degree from Marthandam College of Engineering and Technology, K.K. District, Tamil Nadu, India



A. Sheela is working as Assistant Professor (Senior Grade) in the department of Electrical and Electronics Engineering in Kongu Engineering College, Erode, Tamil Nadu, India. She has a teaching experience of ten years. She has presented a total of seven national and international conferences. Currently she is pursuing her Ph.D in the area of Power System from Anna University Coimbatore, Tamil Nadu, India. She completed her M.E. Degree specialized in Power System from Annamalai University, Chidambaram, Tamil Nadu, India. She completed her B.E. Degree from SONA College of Technology, Salem, Tamil Nadu, India.



S. Josephin Mary is currently pursuing M.E. Degree in Electrical and Electronics Engineering specialized in Power electronics and Drives from PSG College of Technology, Coimbatore, Tamil Nadu, India. She completed B.E. Degree from Marthandam College of Engineering and Technology, K.K. District, Tamil Nadu, India