

The Effects of Auto-Tuned Method in PID and PD Control Scheme for Gantry Crane System

S. Y. S. Hussien, H. I. Jaafar, R. Ghazali, N. R. A. Razif

Abstract—Gantry crane system is a mechanism in heavy engineering that moves payload such container from one point to another. Generally, experienced operators or experts are required to control manually the gantry position while minimizing the payload vibration or swing oscillation. Therefore, those manpower has to be trained in order to operate the gantry crane system safely and efficiently. Thus, to overcome this problem, a feedback control scheme has been utilized in the system. In this paper, PID and PD controllers are introduced for controlling the trolley displacement and the swing oscillation in the gantry crane system. PID controller is designed for tracking the desired position of the trolley whereas PD controller is implemented to minimize the payload oscillation. The PID and PD parameters are tuned by the auto-tuning method. Simulation results have demonstrated satisfactory response based on control system performances.

Index Terms—Auto-tuned, Gantry Crane System, PID and PD Controller, Payload Oscillation, Trolley Position.

I. INTRODUCTION

Gantry crane is widely used in industries for transporting heavy loads and hazardous materials in shipping yards, construction sites, nuclear installations and other application. A crane consists of hoisting mechanism and a reinforcement mechanism. The cable-hook-payload assembly is suspended from one point on the support mechanism. The support mechanism moves the suspension point around the crane workspace, while hoisting mechanism lift and lowers the payload to avoid obstructions in a track and deposit the consignment at the aim level. The crane operation causes a swinging motion to the loads due to crane acceleration and deceleration during travel. This load swing could have many serious consequences such as damage to the surrounding equipment [1-2]. Due to this, a lot of time is needed to unload until the payload stop from swaying. Moreover, the gantry crane need a skillful operator to control manually based on the operator's experience in order to stop the oscillation immediately at the accurate position.

Manuscript Received on January 2015.

S. Y. S. Hussein, Faculty of Electrical Engineering (FKE), Universiti Teknikal Malaysia Melaka (UTeM), Hang Tuah Jaya, 76100 Durian Tunggal, Malaysia.

H. I. Jaafar, Faculty of Electrical Engineering (FKE), Universiti Teknikal Malaysia Melaka (UTeM).

R. Ghazali, Faculty of Electrical Engineering (FKE), Universiti Teknikal Malaysia Melaka (UTeM).

N. R. A. Razif, Faculty of Electrical Engineering (FKE), Universiti Teknikal Malaysia Melaka (UTeM).

As an attempt to control the gantry crane system, several of control techniques have been proposed. In [3-4], those researchers proposed an input shaping technique to control the swing angle. Nevertheless, these methods could not successfully damp the residual swing angle. Not only that, it is sensitive to variation in parameters value about nominal value and changes in initial condition and external disturbance. It also requires a high accuracy in value of the system parameter to achieve a satisfactory system response. Therefore, [5] proposed a technique based on velocity control during the motion. However, this open loop technique is sensitive to the parameters change of the system and incapable to compensate disturbances such as wind. There were many researchers have implemented various control techniques in order to control the position and payload oscillation. One of the controller that had been proposed was Fuzzy Logic Controller (FLC) [6]. It is stated in [7] that FLC requires a complicated sensor at cart which is positioned and load which at swing moment. It is much complicated when the implementation in real application due to the hoisting mechanism that surrounding gantry crane system. Besides, Linear Quadratic Regulator (LQR) is used to minimize the sway angle movement [8]. In that controller approach, LQR is used to eliminate the disturbance effects. However, PID controller is seen good prospect and widely used in industries and nonindustrial applications to control the system for achieving the desired output [9]. However, there have some difficulties in tuning the PID parameters. Traditional tuning methods such as trial and error is an easy way to tune the PID controller but it is not significant and satisfactory performances are not guaranteed. Another tuning method is Ziegler-Nichols that is widely used due to their simplicity [10]. Unfortunately, the way to find the parameters is very aggressive and leads to a large overshoot and oscillatory response. This paper presents the development of an optimal PID controller for control of a nonlinear gantry crane system. In this work, the optimal PID parameters are obtained from the PID auto-tuning method. A control structure with PID controller is proposed for position control of the trolley and PD controller is proposed for the payload oscillation. Simulation results have demonstrated satisfactory responses with the proposed controllers based on control system performances.

II. DYNAMIC MODEL STRUCTURE

In this section, a dynamic model of nonlinear gantry crane is formed in the case of simultaneous operation for both trolley moving and payload lifting or lowering mechanisms. Assume the dynamic model has the characteristics that the payload and the trolley are connected by a massless rigid link.

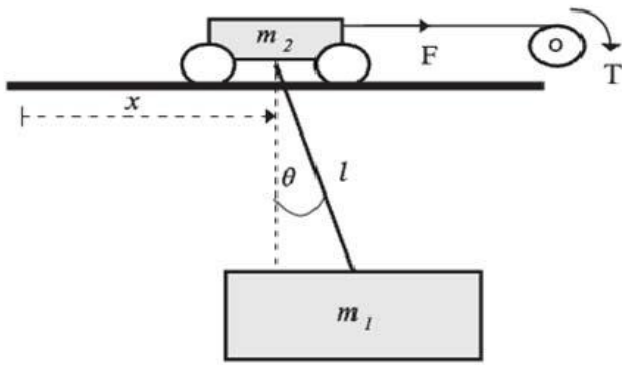

Fig. 1: Dynamic model structure of gantry crane system

The system includes two masses, m_1 and m_2 which are the payload mass and trolley mass. The cable length for supporting the payload mass is represented as in Fig. 1. The system is in a 2-D system which in the x -axis and y -axis coordinate. The x -axis coordinated as for the movement of the trolley in horizontally, which represented as x and y -axis coordinated as for the swaying of payload as represented as θ . The F indicates the force of driving motor in the trolley whereas the torque represented as T .

III. LAGRANGE EQUATION

From the previous study [11-13], it is shown that Lagrange Equation are frequently used to derive the model of the gantry crane system. Therefore, in this paper, the mathematical modeling of the system derived from the Lagrange equation. The Lagrange function is given as (1).

$$L = T - P \tag{1}$$

where:

- L : Lagrangian function
- T : Kinetic energy
- P : Potential energy
- Qi : Nonconcerivative generalized force
- qi : Independent generalized coordinate

The kinetic energy and potential energy of the whole system are:

$$T = \frac{1}{2}m_1[\dot{x}^2 + l^2\dot{\theta}^2 + 2\dot{x}l\dot{\theta}\cos\theta] + \frac{1}{2}m_2\dot{x}^2 \tag{2}$$

$$P = -mgl\cos\theta \tag{3}$$

Constructing (2) and (3) in the (4) and using Lagrange Equation as in (4).

$$\frac{d}{dt}\left[\frac{\partial L}{\partial \dot{q}_i}\right] - \frac{\partial L}{\partial q_i} = Q_i \tag{4}$$

The following equations of motion can be obtained as:

$$(m_1 + m_2)\ddot{x} + m_1l\ddot{\theta}\cos\theta + 2\dot{x}l\dot{\theta}\cos\theta + B\dot{x} - m_2l\dot{\theta}^2\sin\theta = F \tag{5}$$

$$m_1l\ddot{x}\cos\theta + m_1l^2\ddot{\theta} + m_1gl\sin\theta = 0 \tag{6}$$

The force in the (7) derived from the DC motor at the trolley as in (5).

$$F = \frac{VK_t z}{Rr_p} - \frac{K_e K_t z^2}{Rr_p^2} \dot{x} \tag{7}$$

Therefore, the overall model for the system are:

$$(m_1 + m_2)\ddot{x} + m_1l\ddot{\theta}\cos\theta + B\dot{x} - m_1l\dot{\theta}^2\sin\theta = \frac{VK_t z}{Rr_p} - \frac{K_e K_t z^2}{Rr_p^2} \dot{x} \tag{8}$$

$$m_1l\ddot{x}\cos\theta + m_1l^2\ddot{\theta} + m_1gl\sin\theta = 0 \tag{9}$$

IV. PID CONTROLLER

PID controller is a control feedback mechanism controller, which is widely applied in industrial control system. PID controller involves three-term control which is the proportional (P), the integral (I) and the derivative (D). PID controller is utilized to compute an error value as the conflict between a measured process variable and a desired set point. It also applied to minimize the error by correcting the process control inputs.

$$u(t) = K_p e(t) + K_i \int e(t)dt + K_d \frac{de}{dt}(t) \tag{10}$$

$$u(t) = K_p \left[e(t) + \frac{1}{T_i} \int e(t)dt + T_d \frac{de}{dt}(t) \right] \tag{11}$$

In the PID controller, there are three parameters which needed to be tuned. One of the parameters was proportional gain, K_p in the proportional controller. This controller has the effect of reducing the rise time and Steady State Error (SSE) but the percentage of the overshoot (OS) in the system is high. In the integral controller, K_i as the integral gain, also decrease the rise time (T_r), but it will eliminate the SSE of the system. Even though it eliminates the error, but the percentage of the OS is increasing and it will affect the Settling Time (T_s) as well. In order to improve the performance of the system, derivative gain, K_d in the derivative controller is introduced. This controller will take action to improve the transient specification and stability of the system. The effects of the each of the controllers on a closed loop system are summarized in Table 1.

Table 1: PID Controller Properties

	Effect of Performance			
	T_r	T_s	OS	SSE
P	Decrease	Small Change	Increase	Decrease
I	Decrease	Increase	Increase	Eliminate
D	Small Change	Decrease	Decrease	Small Change

In order to gain the high stability and short transient response of the system, the correct gain value must be obtained from the PID tuning. Even though it is only three control parameters, but to adjust the parameter referred to the Table 1 are difficult. Therefore, many methods are implemented in order to obtain the best parameter of PID controller.

A. Auto-tuning Method

PID tuning is the process of finding the values of propotional, integral and derivatives gains of a PID controller to achieve desired performance and meet design requirements. PID controller tuning appears easy, simply determining the set of



Fig. 3: Gantry crane system through simulation

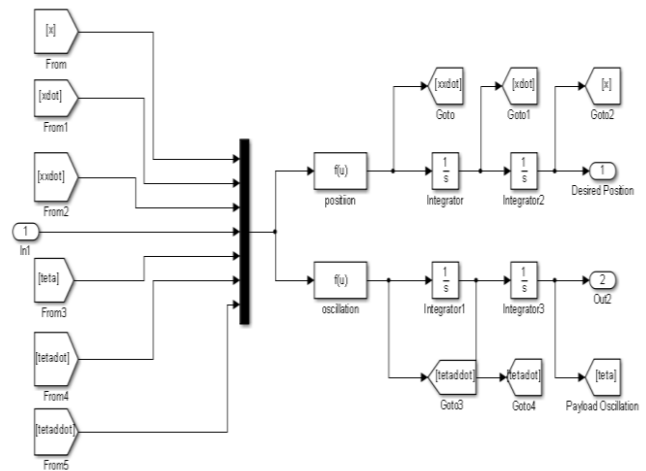

Fig. 4: Subsystem in the gantry crane system

The parameters of the dynamic model show in Table 2.

Table 2: Parameters of gantry crane system

Parameters	Values
Payload mass (m1)	1 kg
Trolley mass (m2)	5 kg
Cable length (l)	0.75 m
Gravitational (g)	9.81m/s ²
Friction (B)	12.32 Ns/m
Resistance (R)	2.6
Torque constant (Kt)	0.007 Nm/A
Electric constant (Ke)	0.007 Vs/rad
Radius of pulley (rp)	0.02 m
Gear ratio (z)	15

gains that to ensure the best operation of the control scheme is a complex text. Traditionally, PID controllers are tuned either manually or using rule-based method. Manual tuning methods are iterative and time-consuming and if used with hardware, it can cause damage. Rule based methods also have serious limitations as it does not support certain types of plant models such as unstable plants, high-order plants or plants with little or no time delay. The PID controllers can automatically tune in order to achieve the optimal system design and meet the design requirements. The process to tune the parameters of PID controller by using an auto-tuned method is shown in Fig. 2.

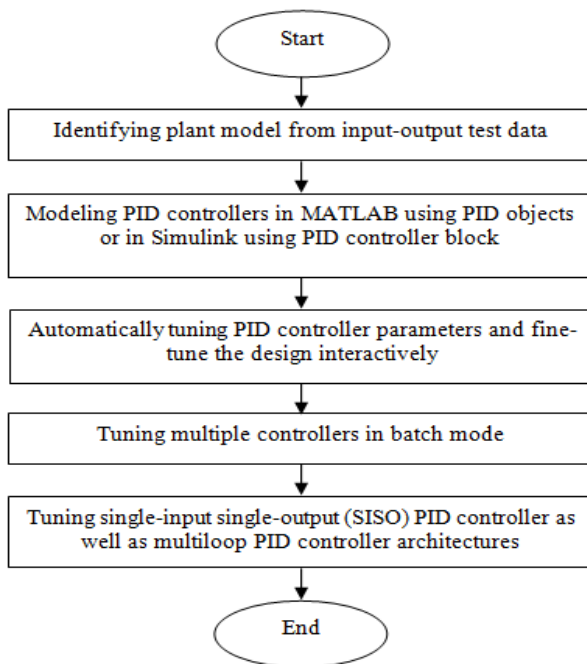
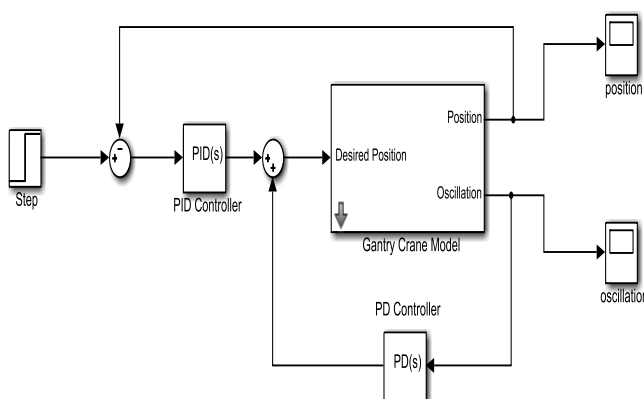

Fig. 2: The process of auto-tuned method for PID controller

V. CONTROLLER DESIGN

The purposed controller consists of PID controller for position control of the trolley and PD control for the payload oscillation control. The gantry crane system model is simulated with the development of mathematical equation in (8) and (9) by using MATLAB and Simulink environment. Simulink blocks that consist of the mathematical equation are shown in Fig. 3 while Fig. 4 shows the subsystem in the gantry crane block.



VI. RESULTS AND DISCUSSIONS

The simulation results have been compared and discussed in this section. Fig. 5 shows the response of open loop system for the trolley to achieved desired position which is 1 m without implementing controller, whereas Fig. 6 shows the response of open loop system for the payload oscillation without implementing controller.

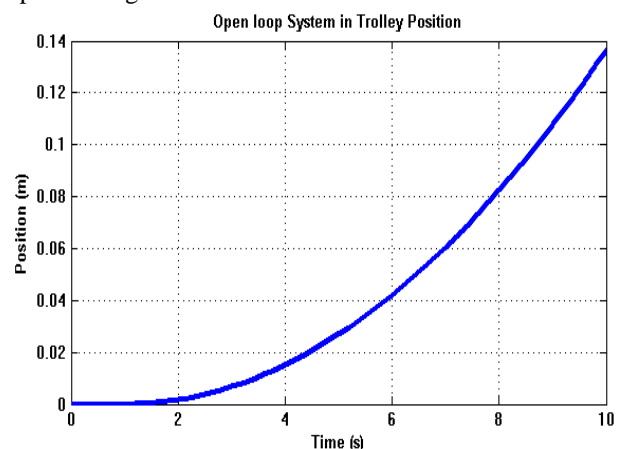

Fig. 5: The open loop system in trolley position

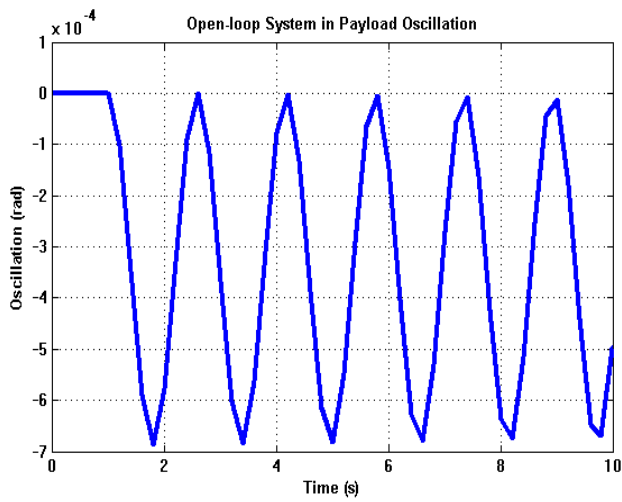

Fig. 6: The open loop system in payload oscillation

Fig. 7 and 8 show the performance by adjusting the parameters of PID controller (K_p , K_i , K_d) to control the trolley position in order to achieve the desired position which is 1 m. Moreover, Fig. 9 and 10 show the performance by adjusting the parameters of the PD controller (K_{ps} , K_{ds}) to minimize the payload oscillation. Table 3 and 5 show the value of parameters in PID and PD control while Table 4 and 6 show the transient response of the system.

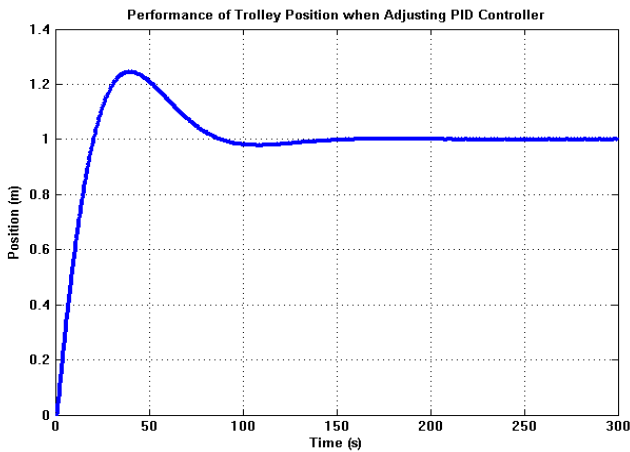

Fig. 7: Performance of the trolley position when adjusting PID controller

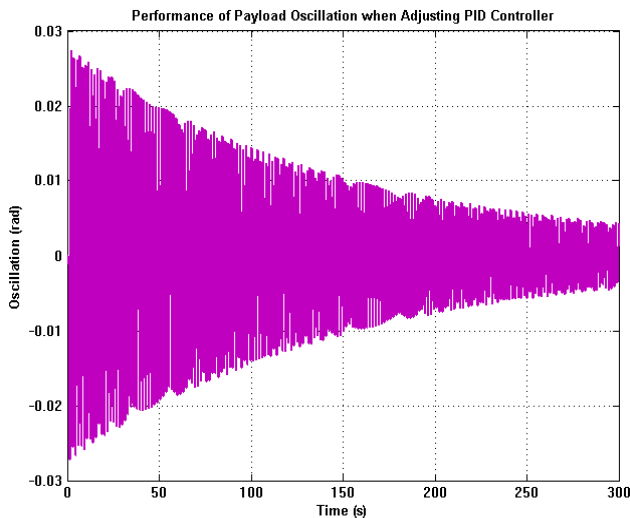

Fig. 8: Performance of the payload oscillation when adjusting PID controller

Table 3: The parameter value by adjusting PID controller

Parameter	Value
K_p	1.0295
K_i	0.0007425
K_d	21.6322

Table 4: The performance by adjusting PID controller

Response	Value
Settling time, T_s (s)	115
Overshoot, OS (%)	24.4
Steady-state error, SSE (m)	0.00

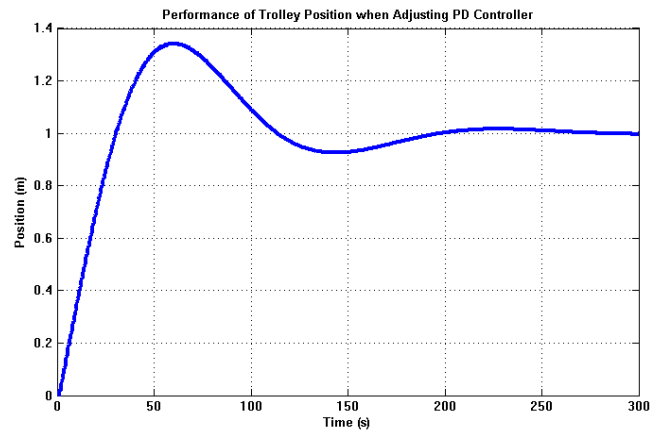

Fig. 9: Performance of the trolley position when adjusting PD controller

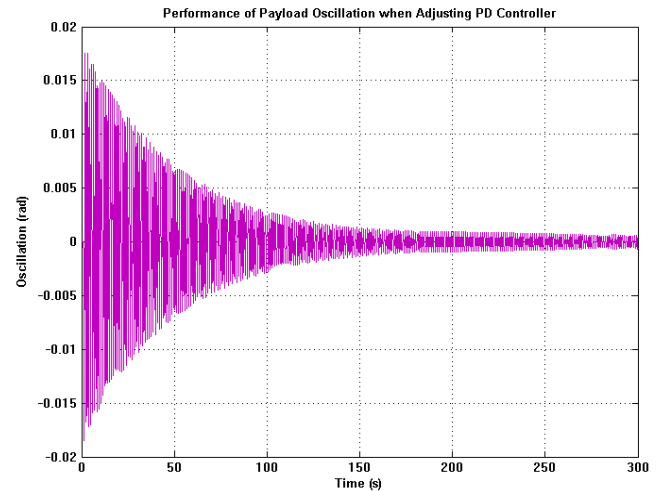

Fig. 10: Performance of the payload oscillation when adjusting PD controller

Table 5: The parameter value by adjusting PID controller

Parameter	Value
K_{ps}	2815.4133
K_{ds}	0

Table 6: The performance by adjusting PID controller

Response	Value
----------	-------

Angle (rad)	0.0185
Time (s)	188

VII. CONCLUSION

PID Tuner provides a fast and widely applicable single-loop. With this method, the PID controller parameters can be chosen to achieve a robust design with the desired response time. When launching the PID tuner, the software automatically computes a linear plant model from the Simulink model and designs an initial controller. Then, the controller can be adjusted manually in the PID tuner based on the design criteria in two design modes. The tuner computes PID parameters that robustly stabilize the system. Lastly, it will export the parameters of the designed controller back to the PID controller block and verify controller performance in Simulink. PID and PD controller is used to control the position and reduce the payload oscillation in a gantry crane system. The controller is constructed in closed loop and insensitive to the parameter changes in the system. Through the simulation results, it is shown that the proposed controller is effective in achieving the desired position while minimizing the payload oscillation. However, by using the auto-tuned method, both of the controllers are incapable to be tuned simultaneously. Therefore, for future work, an advanced approach should be implemented in the system to overcome this problem.

VIII. ACKNOWLEDGMENT

The authors would like to thank the Ministry of Education (MOE) and Universiti Teknikal Malaysia Melaka (UTeM) for sponsoring this project. This project is funded by the Fundamental Research Grant Scheme (FRGS) Grant No. FRGS/1/2014/TK03/FKE/03/F00213 and Short Term Research Grant No. PJP/2013/FKE(25C)/S01256.

REFERENCES

- [1] H. Butler, G. Honderd, and J. van Amerongen, "Model reference adaptive control of a gantry crane scale model," *Control Systems*, IEEE, vol. 11, pp. 57-62, 1991.
- [2] D. Diep and V. Khoa, "PID-Controllers Tuning Optimization with PSO Algorithm for Nonlinear Gantry Crane System," *system*, vol. 2, p. 7.
- [3] Garrido, Santiago, et al. "Anti-swinging input shaping control of an automatic construction crane." *Automation Science and Engineering*, IEEE Transactions on 5.3 (2008): 549-557.
- [4] Daqaq, Mohammed F., and Ziyad N. Masoud. "Nonlinear input-shaping controller for quay-side container cranes." *Nonlinear Dynamics* 45.1-2 (2006): 149-170.
- [5] Gupta, S., and P. Bhowal. "Simplified open-loop anti-sway technique." *India Annual Conference, 2004. Proceedings of the IEEE INDICON 2004. First*. IEEE, 2004.
- [6] Wahyudi, Wahyudi, and Jamaludin Jalani. "Design and implementation of fuzzy logic controller for intelligent gantry crane system." (2005).
- [7] Zawawi, M. A., et al. "Feedback control schemes for gantry crane system incorporating payload." *Industrial Electronics and Applications (ISIEA), 2011 IEEE Symposium on*. IEEE, 2011.
- [8] Ahmad, M. A., et al. "Control schemes for input tracking and anti-sway control of a gantry crane." *Australian Journal of Basic and Applied Sciences* 4.8 (2010): 2280-2291.
- [9] S. Gade, S. Shendage, and M. Uplane, "MATLAB Based Response of Systems Using Auto Tune PID Controller," *International Journal of Emerging Technology and Advanced Engineering (ISSN 2250-2459, ISO 9001: 2008 Certified Journal, Volume 2, Issue 12*, pp. 157-162, 2012.
- [10] O. Katsuhiko, "Modern control engineering," 2010.

- [11] M. Ahmad, R. Raja Ismail, A. Nasir, and M. Ramli, "Anti-sway control of a gantry crane system based on feedback loop approaches," in *Advanced Intelligent Mechatronics, 2009. AIM 2009. IEEE/ASME International Conference on, 2009*, pp. 1094-1099.
- [12] M. Gaiceanu and F. Stan, "Motion control of a single-beam gantry crane trolley," in *Electrical and Electronics Engineering (ISEEE), 2010 3rd International Symposium on*, 2010, pp. 149-152.
- [13] Jaafar, H.I., Mohammed, Z., Jamian, J.J., Abidin, A.F.Z., Kassim, A.M., Ghani, Z.A., "Dynamic Behaviour of a Nonlinear Gantry Crane System," *Procedia Technology*, vol. 11, pp. 419-425, 2013.



Sharifah Yuslinda Syed Hussien, received her B.Eng degree in Electrical Engineering from Universiti Teknikal Malaysia Melaka (UTeM), in 2014. Currently, she pursues her study in Master of Science in Electrical Engineering, UTeM.



Hazriq Izzuan Jaafar, received his B.Eng degree in Electrical Engineering from Universiti Teknologi Malaysia (UTM), in 2008. He received the M.Eng degree in Mechatronics and Automatic Control engineering also from UTM, in 2013. Currently, he is a Lecturer at Universiti Teknikal Malaysia Melaka (UTeM) and his interests are in control system and optimization techniques.



Rozaimi Ghazali, received his B.Eng degree in Electrical Engineering (Instrumentation and Control) from Universiti Teknologi Malaysia (UTM), in 2008. He received the Ph.D in Electrical Engineering also from UTM, in 2013. Currently, he is a senior lecturer at Universiti Teknikal Malaysia Melaka (UTeM) and his interests are in system identification and robust controller design.



Nur Rafiqah Abdul Razif, received her B.Sc degree in Industrial Mathematics from Universiti Teknologi Malaysia (UTM), in 2010. He received the M.Sc degree in Mathematics also from UTM, in 2012. Currently, she is a Lecturer at Universiti Teknikal Malaysia Melaka (UTeM) and his interests are in Operational Research and Statistics.